

bühler

allied

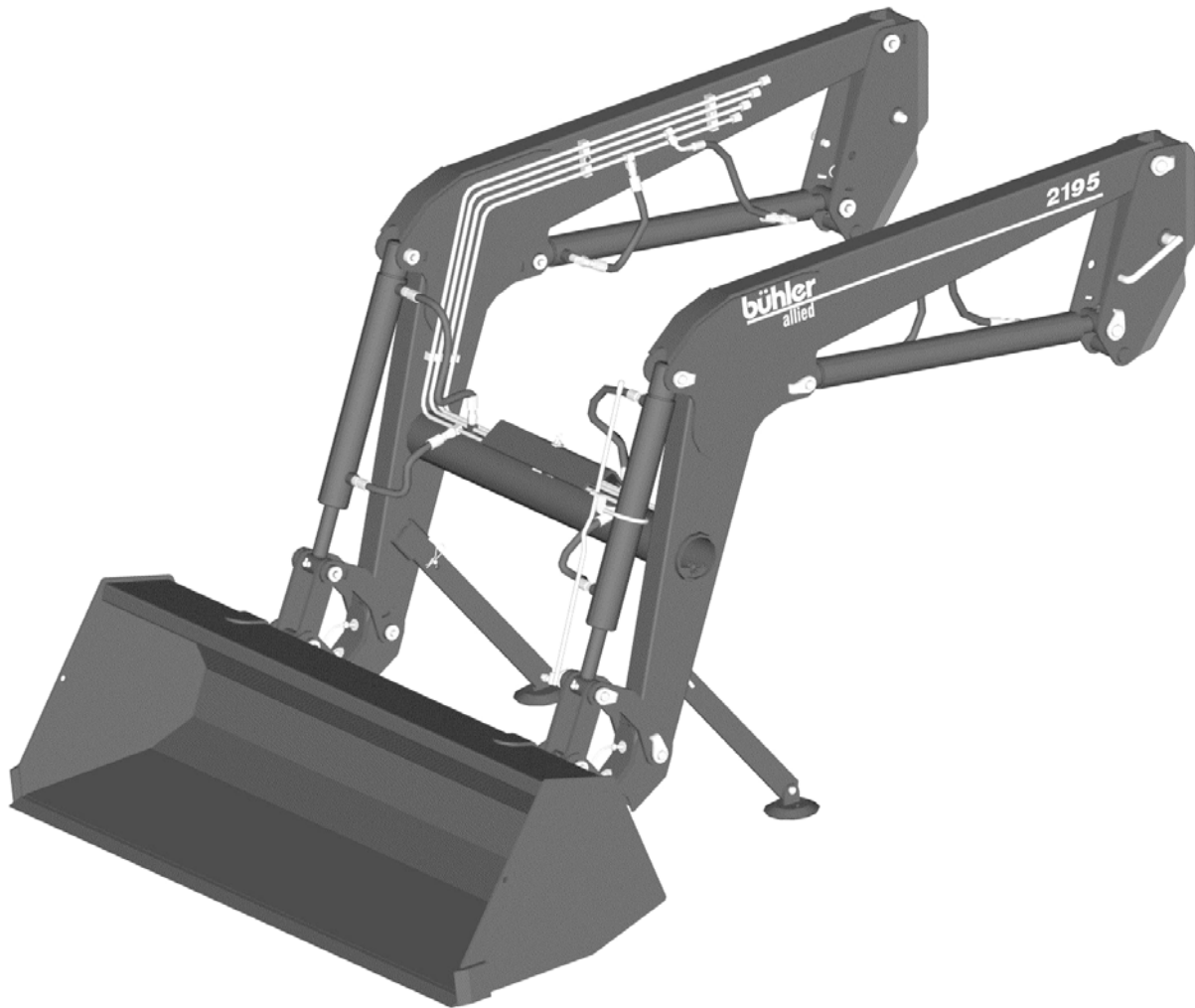

Model 2195

Operator's and Parts Manual
Front-End Loader
P4412

WARRANTY REGISTRATION AND POLICY

Buhler Manufacturing products are warranted for a period of twelve (12) months from original date of purchase, by original purchaser, to be free from defects in material and workmanship under correct, normal agricultural use and proper applications.

Buhler Manufacturing's obligations under this warranty shall be limited to the repair or exchange, at Buhler Manufacturing's option, of any Buhler Manufacturing product or part which proves to be defective as provided. Buhler Manufacturing reserves the right to either inspect the product at the buyer's location or have it returned to the factory for inspection.

The above warranty does not extend to goods damaged or subject to accident, abuse or misuse after shipment from Buhler Manufacturing's factory, nor to goods altered or repaired by anyone other than an authorized Buhler Manufacturing representative.

Buhler Manufacturing makes no Express Warranties other than those which are specifically described. Any description of goods, including any references and specifications in catalogues, circulars and other written material published is for the sole purpose of identifying goods and shall conform to such descriptions. Any sample or model is for illustrative purposes only and does not create an Express Warranty that the goods conform to sample or model shown.

The purchaser is solely responsible for determining suitability of goods sold. This warranty is expressly in lieu of all other warranties expressed or implied. Buhler Manufacturing will in no event be liable for any incidental or consequential damages whatsoever, nor for any sum in excess of the price received for the goods for which liability is claimed.

WARRANTY CLAIMS:

Warranty requests must be prepared on Buhler Manufacturing Warranty Claim Forms with all requested information properly completed. Warranty Claims must be submitted within a thirty (30) day period from date of failure repair.

WARRANTY LABOR:

Any labor subject to warranty **must** be authorized by Buhler Manufacturing. The labor rate for replacing defective parts, where applicable, will be credited at a rate determined by the Company, Buhler Manufacturing.

IMPORTANT FACTS:

Buckets and Bucket Tines Carry No Warranty

Bent Spears Carry No Warranty

Snowblower Fan Shafts Carry No Warranty

Mower Blades Carry No Warranty

Portable Auger Parts Have Two (2) Year Warranty

Loader Parts Have Two (2) Year Warranty

2195 OPERATOR'S AND PARTS MANUAL

Table of Contents

Description	Page
Registration and Policy	
Loader Specifications	2
Introduction	
Terminology	4
Safety	
General Safety Notes	6
Important Precautions	7
Safety Decals	8
Pre – Operation	10
Operation	
General Operating Notes	11
Hydraulics	11
Bucket	12
Backfilling or Scraping	13
A – Frame	14
Handling Bales and Pallets	15
Installing / Removing Loader	
Installing	17
Removing	18
Lubrication	20
Maintenance	
General Inspection	21
Lift locks	21
Pins and Bushings	21
Mounting Kit	22
Bolt Torque Chart	22
Hydraulics	23
Trouble Shooting	26
Parts Appendix	28

LOADER SPECIFICATIONS

Illustration (2195 Loader)

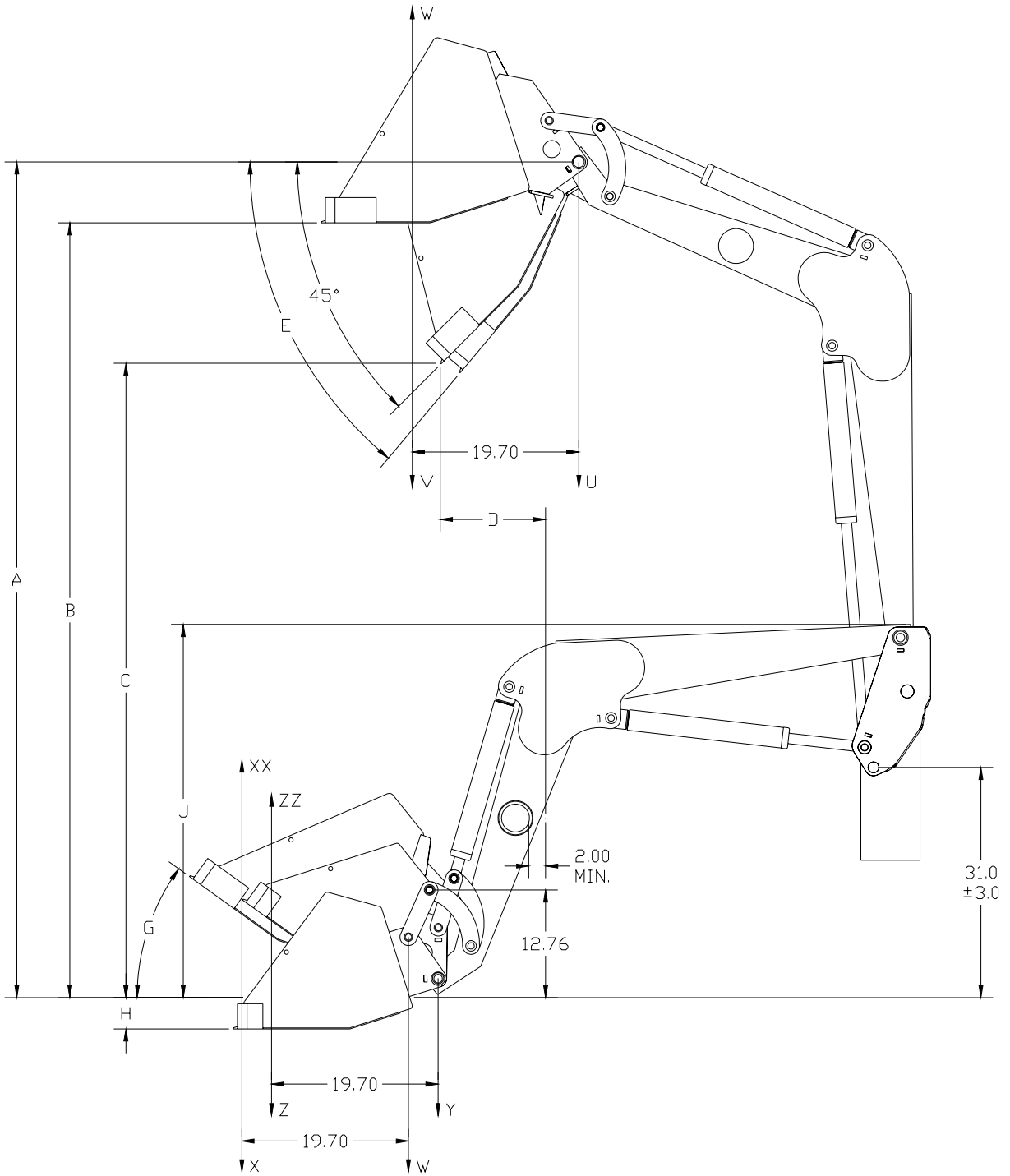

Specification Chart

Item	Description	2195 REG
A	Maximum lift height to pivot pin [in/cm]	102/259
B	Maximum lift height under level bucket [in/cm]	97/246
C	Clearance with bucket dumped [in/cm]	81/206
D	Reach at maximum lift height [in/cm]	30/76
E	Maximum dump angle [deg]	50
G	Maximum rollback angle [deg]	36
H	Digging depth [in/cm]	4/9
J	Overall height in carry position [in/cm]	48/122
U	Lift capacity to maximum height - at pivot pin [lb/kg]	1295/587
V	Lift capacity to maximum height [lb/kg]	853/387
W	Lift capacity to 59 in. height - at pivot pin [lb/kg]	1625/737
X	Lift capacity to 59 in. height [lb/kg]	1255/569
Y	Breakout force - at pivot pin [lbf/daN]	2360/1050
Z	Breakout force [lbf/daN]	1738/773
VV	Bucket rollback force at maximum height [lbf/daN]	1389/618
XX	Bucket rollback force at 59 in. lift height [lbf/daN]	2216/986
ZZ	Bucket rollback force at ground line [lbf/daN]	1891/841
	Raising/Lowering time [sec]	5
	Bucket dumping/rollback time [sec]	4.7/3.3
	Lift cylinder tube/shaft size [in]	2.00/1.50
	Lift cylinder stroke/retracted length [in]	18.50/29.25
	Bucket cylinder tube/shaft size [in]	2.0/1.25
	Bucket cylinder stroke/retracted length [in]	13.38/23.63
	Mounting Height (+/- 3.0) [in]	31.0
	Hydraulic pressure rating/flow rate [psi]/[gpm]	2000/5
	Tractor size [H.P. @ normal duty]	20-35
	Bucket size [in/cu.ft.]	48/6.3
	- * Indicates bucket size used for calculations of lift capacities and rollback forces.	60/7.9
	Weight (with bkt & mtg kit) [lb]	600

NOTE: Specifications are subject to change without notice or obligation.

INTRODUCTION

This manual has been provided as information regarding the specifications, safe operation and maintenance of your agricultural front-end loader. Read and understand this manual and the *tractor manual* prior to operating to obtain the best use of operating your loader. Keep this manual for reference and to forward to new operators and owners. Contact your local Buhler - Allied dealer if you require any assistance, information or additional manuals.

Terminology: Basic terminology used throughout this manual has been identified below. For part numbers and further details refer to the Parts Appendix.

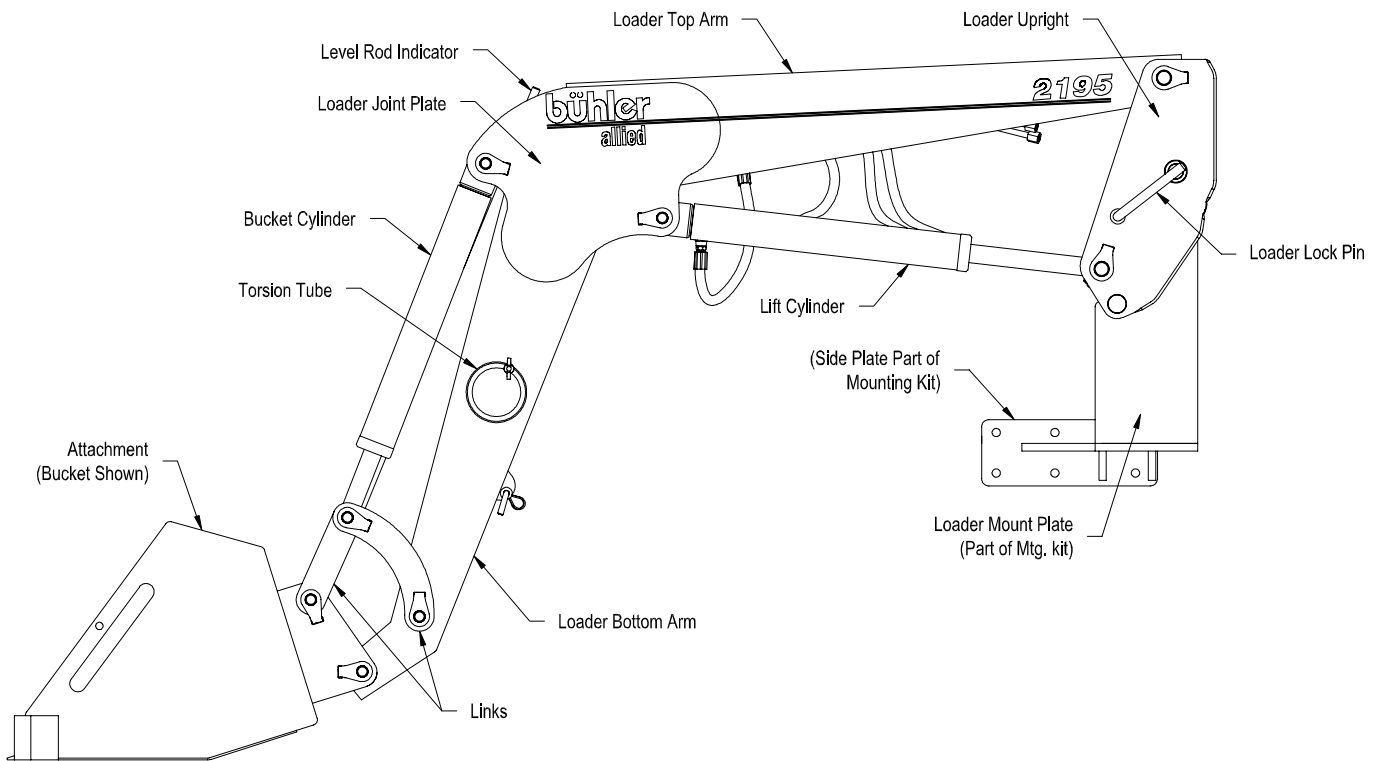

Loader Identification Illustration (2195 shown)

Some components are identified as “right” and “left”. This is determined as seated in the tractor and facing forward, loader end.

Serial Decal Location: The serial decal is located on the inside left arm of the loader joint plate. Please record the serial number in the space provided for future reference. The serial decal will provide the model and date of manufacture of the loader and will be required to obtain correct replacement parts and complete warranty claims.

For your records, record
Serial Number here: _____

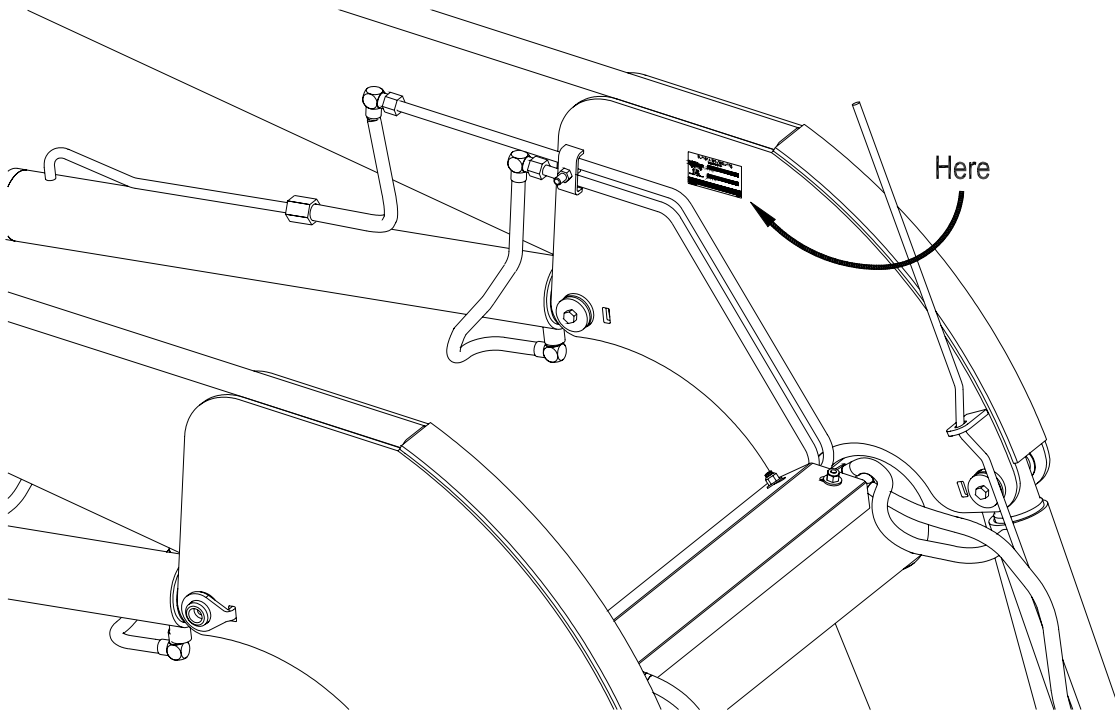
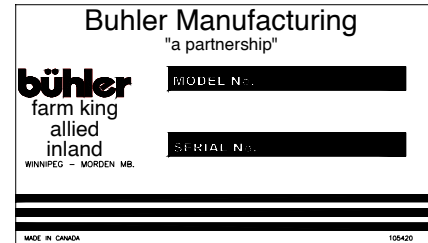

Warranty Registration: The *Warranty Registration and Delivery Report* **MUST** be completed within thirty (30) days of delivery to validate the warranty.

SAFETY

Read and understand all the safety messages listed in this manual. For your safety and the safety of others near the machine, learn how to control and operate the loader properly. It is your responsibility to inform subsequent operators and owners of these precautions.

General Safety Notes:

- ✓ Improper use of the loader and tractor can cause serious injury or death.
- ✓ Operate the loader while seated in the tractor seat only.
- ✓ Keep the work area clear of other persons.
- ✓ Never leave the tractor unattended while the attachment is raised. Always lower the attachment to ground and shut tractor off before leaving the tractor seat.
- ✓ Never work beneath a raised loader unless it is securely supported. The control lever can be moved or a hydraulic leak could cause the loader to drop resulting in serious injury or death. Refer to the *Lift Lock Instructions Decal* for proper use of the lift locks.
- ✓ Prior to use, check to ensure the attachment is properly locked to the quick-tach. Verify from tractor seat by lowering the attachment to the ground and retracting the lift cylinders.
- ✓ Never operate loader with frayed or damaged hoses or leaking fittings. A burst could cause the loader to drop suddenly and result in serious injury or death and cause damage to the loader or tractor.
- ✓ Keep tractor on solid ground when raising loader. Loose fill rocks and holes can be dangerous for loader operation and movement.
- ✓ If for some reason, you feel the tractor tipping, immediately lower the loader.
- ✓ A pivoting front axle acts like a three-wheeled tractor until the stops hit the axle.
- ✓ Space rear tires as recommended by the tractor manufacturer. Maximize width for high lift applications and uneven terrain.
- ✓ Add rear ballast as required to ensure 25% of gross vehicle weight is transferred to the rear axle. Loader, attachment and payload must be included as weight.
- ✓ Do not raise attachment to extreme heights while tractor is on an incline. Be alert for terrain changes and adjust accordingly. Keep attachment at low travel height, no more than one foot, as long as possible.
- ✓ Allow for attachment and loader length when turning.
- ✓ The tractor must be equipped with an approved Roll Over Protection Structure (ROPS) and safety belts.
- ✓ Use proper lighting and safety warnings when transporting equipment on public roads and during darkness. The Slow Moving Vehicle (SMV) emblem must be visible. Check with your local Law Enforcement Agency for specific requirements.

Safety Decals: *Safety Decal Location* illustrates the approximate location and detail of safety decals. To install safety decals ensure the installation area is clean and dry. Decide on the exact position before you remove the backing paper. Remove the smallest portion

of the split backing paper and align over the specified area. Carefully press in place. Slowly peel back the remaining paper and smooth the remaining portion in place. Small air pockets can be pierced with a pin and smoothed out. Keep all decals clean and replace any that are damaged or missing. Replacement decals are available from your local dealer.

Important Precautions: The alert symbol is used throughout this manual. It indicates attention is required and identifies hazards; your safety is involved. Follow the recommended precautions.



The safety alert symbol indicates ATTENTION ! BECOME ALERT ! YOUR SAFETY IS INVOLVED ! The symbol appears in conjunction with statements and signs.

CAUTION

The caution symbol indicates a potentially hazardous situation, which may result in injury. It may also be used to alert against unsafe practices.

WARNING

The warning symbol indicates a potentially hazardous situation, which could result in death or serious injury and includes hazards that are exposed when guards are removed. It may also be used to alert against unsafe practices.

DANGER

The danger symbol indicates an imminently hazardous situation, which will result in death or serious injury. This signal word is limited to the most extreme situations, typically for machine components, which, for functional purposes, cannot be guarded.

Safety Decal Location

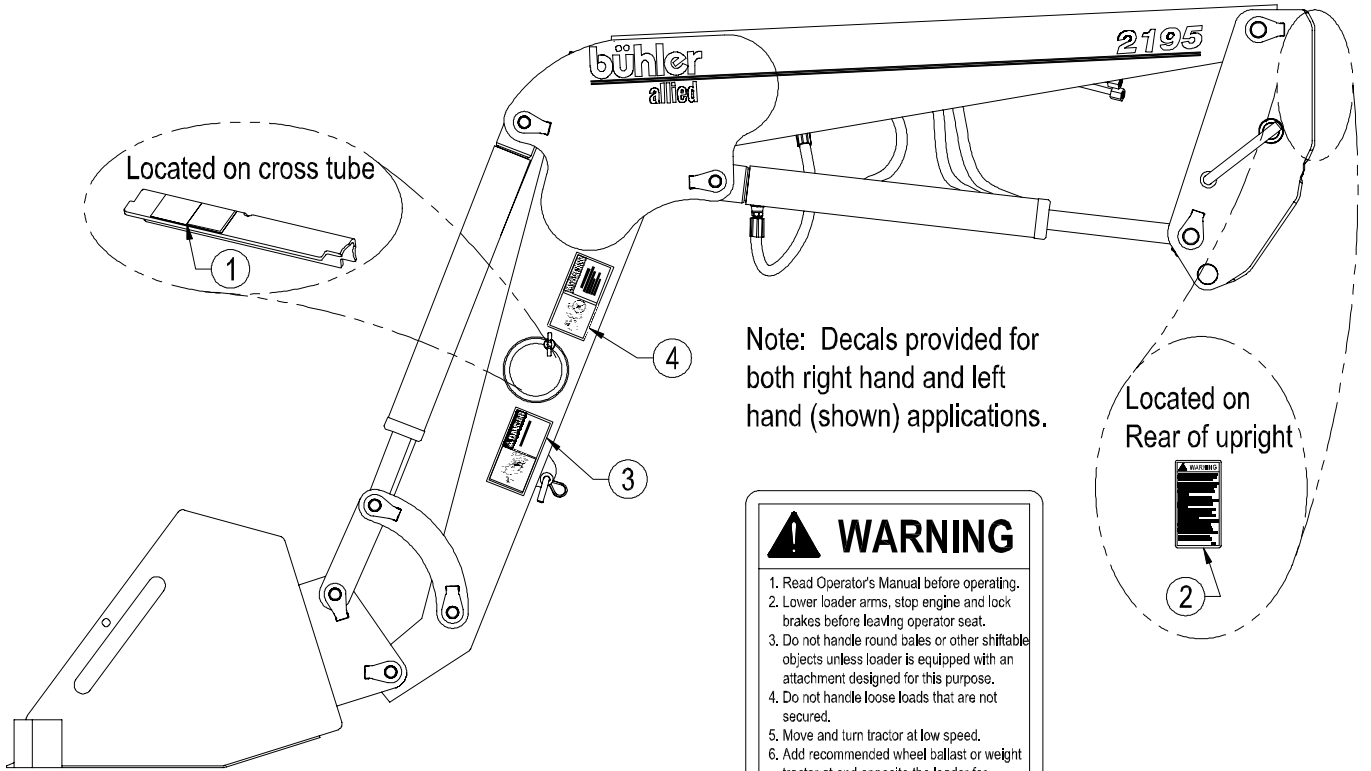

Note: Decals provided for both right hand and left hand (shown) applications.

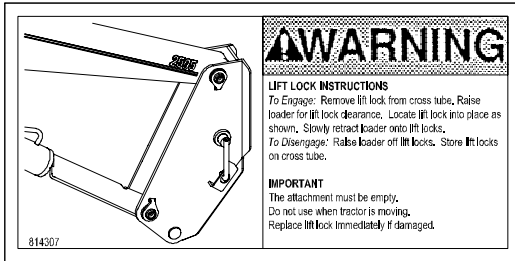

① Part # 814307

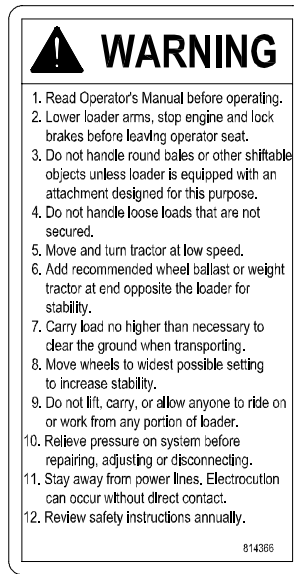

② Part # 814366

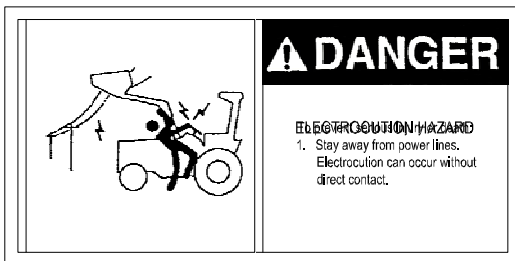

③ Part # 113711

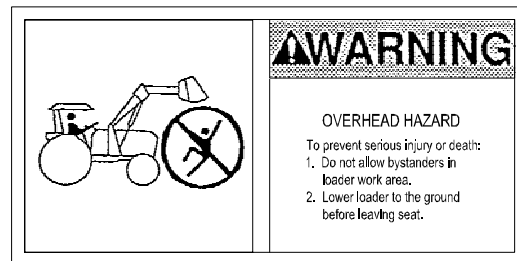

④ Part # 112983

The following pictorials indicate important precautions to be used during the operation of the loader.

⚠ DANGER

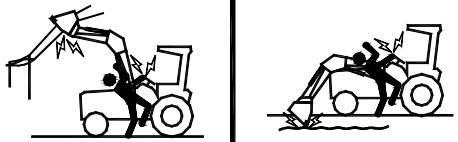

ELECTROCUTION HAZARD
To prevent serious injury or death:

Stay away from power lines and cables. Electrocution can occur with or without direct contact.

⚠ WARNING



FALLING HAZARD
To prevent serious injury or death:

Do not lift, carry or allow anyone to ride on or work from any portion of loader.

⚠ WARNING



CRUSHING HAZARD
To prevent serious injury or death:

Do not handle round bales or other shiftable objects unless loader is equipped with an attachment designed for this purpose.
Do not handle loose loads that are not secured.
Do not lift load higher than necessary.

⚠ WARNING

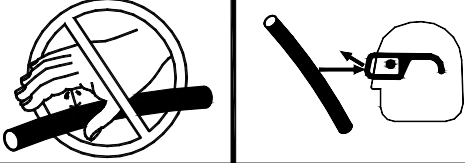

HIGH PRESSURE FLUID
To prevent serious injury or death:

Relieve pressure on system before repairing or adjusting or disconnecting.
Wear proper hand and eye protection when searching for leaks. Use wood or cardboard instead of hands.
Keep all components in good repair.
If hydraulic fluid penetrates skin, obtain medical treatment IMMEDIATELY.

⚠ WARNING

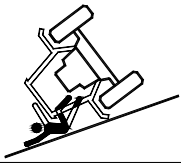

ROLL-OVER HAZARD
To prevent serious injury or death:

Move and turn tractor at low speed.
Carry load no higher than necessary to clear the ground when transporting.
Add wheel ballast or rear weight for stability.
Move wheels to widest possible settings to increase stability.
It is recommended the tractor be equipped with a rollover protective structure (ROPS).

⚠ WARNING



CRUSHING HAZARD
To prevent serious injury or death:

Do not allow bystanders in loader work area.
Lower loader to the ground before leaving seat.
Do not walk or work under raised loader. For servicing, refer to operator's manual.
Read and understand operator's manual before operating loader.

PRE – OPERATION

⚠ WARNING The tractor must be equipped with an approved Roll over Protection Structure (ROPS) and safety belts to help prevent personal injury or death caused by tractor roll over.

⚠ CAUTION Maximum rated loader capacity may exceed tractor rating. Load restrictions or reduction in hydraulic operating pressure may be required for safe operation.

Rops: Do not exceed the manufacturer's rating for maximum gross vehicle weight. Refer to the *Tractor Manual* or the *ROPS Serial Decal* for rating. Do not alter or modify the ROPS structure.

Tractor Tires: Space rear tires as recommended by the tractor manufacturer. Tire inflation and capacity must meet or exceed additional weight of loader, attachment and payload. Maximize width for high lift applications. Tread width must not exceed maximum width as recommended in the *Mounting Kit Listing*.

⚠ WARNING Add rear ballast to help prevent personal injury or death caused by tractor roll over.

Rear Ballast: Rear ballast is required to ensure 25% of gross vehicle weight is transferred to the rear axle. Attachment and load must be included as weight. Adequate rear weights are required to counterbalance maximum loader capacity and safe loader operation. Weight can be added as rear tire liquid (calcium solution), rear wheel weights, rear axle weights and/or three point hitch mounted ballast or implement. Ballasting will vary with tractor and loader attachment. Refer to the *Tractor Manual* for recommended ballasting.

OPERATION

General Operating Notes: The following section provides general information that can be applied towards your specific application. Ensure that you've read and understood this manual and your *Tractor Manual*. Observe all safety precautions and follow local laws pertaining to the use of your loader and tractor.

Hydraulics: Under normal conditions, operate the tractor's engine at ½ throttle.

Note: *In cold weather, tractors with load sense hydraulic systems require longer warm-up periods for the loader to respond when valve is operated.*

In cold weather, operate the tractor's engine at idle speed until the hydraulic fluid is warmed up. Slowly cycle the loader and attachment several times to further warm the hydraulic fluid. High engine speed when the hydraulic fluid is cold will cause the pump to wear prematurely and may cause the loader to operate erratically.

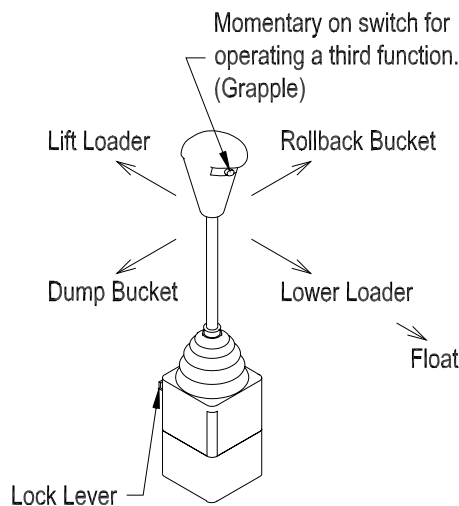
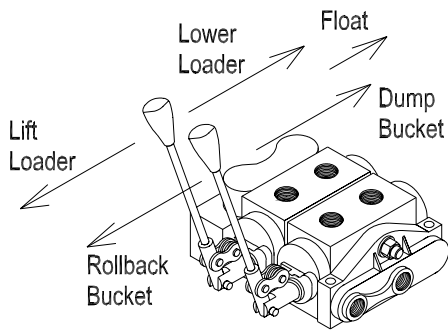

The hydraulic hoses should be connected to the loader valve such that pushing forward on handles lowers the loader or dumps the attachment. When using the *Allied Remote Hydraulic Control* pushing forward should lower the loader while pushing directly right should dump the attachment.

The *Allied Remote Hydraulic Control* is equipped with a momentary push button switch and a lock. The push button is for operating a third function when an electric diverter is installed. The third function is normally for operating a grapple. When the button is depressed the valve ports are open to the grapple cylinders. Shifting the joystick to the left while button is depressed will close the grapple and shifting to the right will open.

IMPORTANT: *Always feather the grapple when closing or opening to avoid unnecessary shock loads on grapple components.*

WARNING

Keep grapple closed at all times when bucket is empty and carry bucket low to the ground. Avoid operating near power wires.

All *Buhler-Allied* hydraulic valves are self-centering and return to neutral from all positions except float. The float or detent spool is only to be used on the boom circuit. This position allows the oil to freely flow through the valve so the lift cylinders can extend or retract. It can be engaged by slightly pushing control beyond full lower. Float will allow for the loader to lower and rise as the attachment follows the ground contours. To disengage float, slightly pull control back towards the neutral position. The *Allied Remote Hydraulic Control* can be locked in the neutral position to minimize unintentional movement.

⚠ CAUTION Lower and dump heavy loads slowly by feathering. Stop tractor movement gradually. Never drop a loaded attachment and “catch” hydraulically. Stopping with such downward momentum may cause damage to the loader or tractor.

When handling heavy loads be sure to raise and lower the loader slowly while leveling the attachment as required. Feathering can assist in accurately controlling operations by regulating oil flow through cylinders.

A third function hydraulic control is available for grapple or other hydraulic applications. An optional divertor valve is connected to the loader attachment spool and is operated via the *Allied Remote Hydraulic Control* momentary switch and simultaneously engaging the bucket spool through dump or rollback.

Bucket:

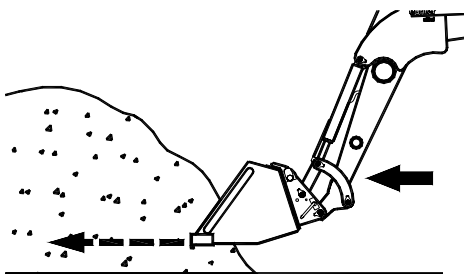

When loading a bucket, approach straight and enter the pile with a level bucket parallel to the line of motion.

IMPORTANT: Attempting to turn while loading may cause damage to the loader or tractor.

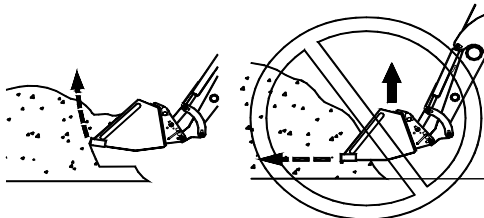

Work controls to raise and rollback the bucket simultaneously. The combined actions of lift and bucket cylinders increases loading efficiency and minimizes resistance to lift.

NOTE: On tractors with low hydraulic oil flows, both functions may not be possible

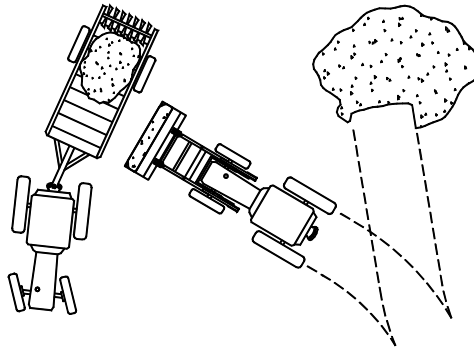

Minimize turning angle and length of run between pile and trailer to increase loading efficiency. Also, place load evenly or centered in the attachment.

⚠ WARNING Carry the load no higher than necessary to clear the terrain. Turn and brake slowly. Always be sure that loading area is level and on solid ground. Do not raise loader higher than required while dumping. Immediately lower the loader to ground if the tractor becomes unstable.

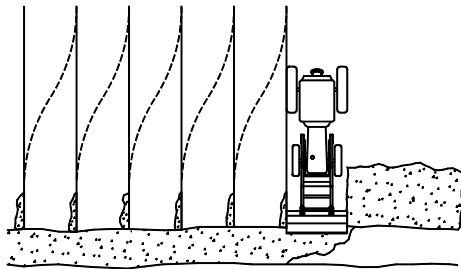

Leave material, which drifts over the bucket sides for final cleanup.

Backfilling or Scraping:

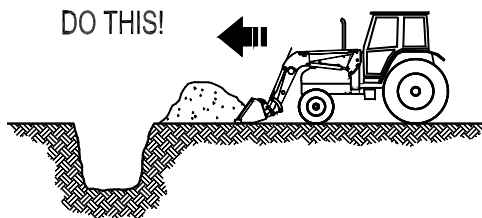

For forward back filling, approach pile with a level bucket. Utilize the float position to minimize bucket cutting edge wear. Leave dirt in bucket. Dumping on each pass reduces efficiency.

NOTE: Use leveling rod for a guide to ensure bucket is level.

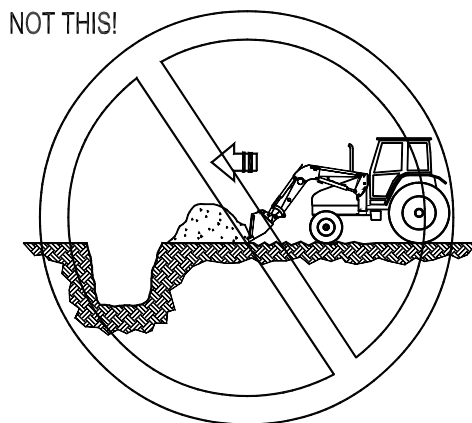

Do not use bucket in dumped position for forward grading. This will only impose severe shock loading on the bucket cylinders and it is difficult to maintain a level grade.

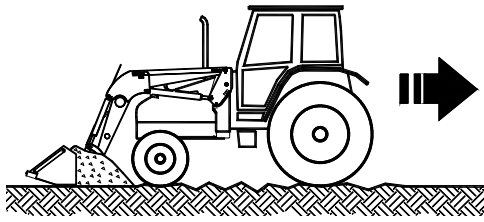

For back grading, either load the bucket and position the heel on the ground or position the bucket at 40° or less below level as shown. Place the valve in the float position and back up slowly.

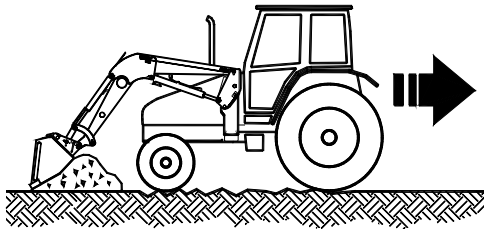

IMPORTANT: Float position must be used to reduce down pressure, otherwise cylinder rod(s) and/or bucket damage could occur.

A – Frame: Standard and Heavy Duty A – Frames can be fitted with either spears or pallet forks.

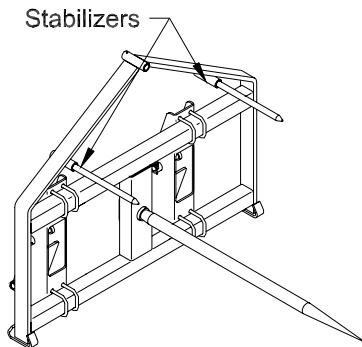

- Standard Duty

The standard duty frame is for handling medium sized round bales (up to 1000 lbs.) fitted with a single centered 1240mm long heat treated spear and two short stabilizers. For pallet applications with a maximum load up to 2000 lbs. when fitted with 42.0" fork kit.

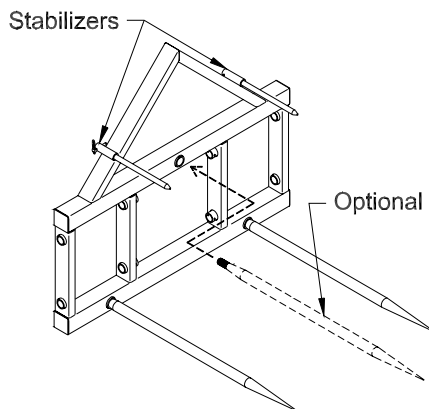

- Heavy Duty 60"

The Heavy Duty 60" frame is for handling medium to large sized round bales (up to 2000 lbs.) when fitted with two bottom 1240mm long heat treated spears and two short stabilizers. For pallet applications with a maximum payload of 4400 lbs. when fitted with the 48.0" fork kit.

NOTE: The heavy duty frame can also be fitted using only the one center spear as per the standard duty A-frame.

Handling bales and pallets:

For safe handling of bales and pallets please follow procedures below:

WARNING

Do not operate A – Frame for bales without the stabilizers.

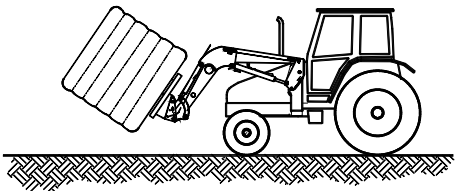
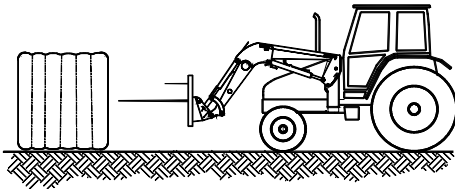

With a single spear, enter one of the ends of the bale and drive the spear horizontally into the center or slightly above center of the bale and fully penetrate the bale. Then rollback the bucket cylinders approximately three quarters of the cylinder stroke and lift bale approximately a foot off the ground.

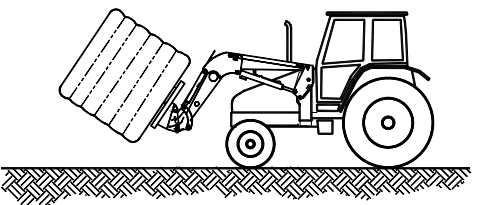
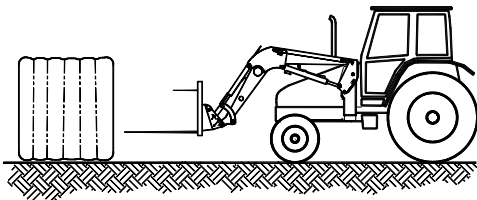

With the double or four spears enter the bale from one of the ends and drive the spear one third to one half the way up, from the bottom and fully penetrate the bale. Then rollback the bucket cylinders approximately three quarters of the cylinder's stroke and lift bale approximately 12.0" off the ground.

CAUTION

Never attempt to use the spears as forks, as the spears can easily penetrate the ground causing a spear to bend or break as well as making the bale unstable to carry. Never attempt to handle a bale with only part of the spear(s) penetrated. The nut on the bale spear must be torqued to 500 ft.-lbs. Check the torque periodically. A loose spear will damage the spear holder.

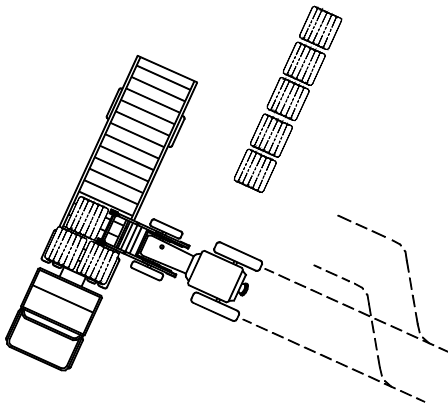

When loading bales onto a trailer, park trailer in close proximity to minimize turning angle and length of travel to increase loading efficiency.

As you lift the bale using the regular loader, it is recommended to feather the valve to allow bucket cylinders to extend to keep bale at about a 20° angle. (On TSL loaders this is not necessary) Lift the bale only enough to clear the area that the bale will be placed on. Always approach the trailer square to the tractor as shown.

⚠ CAUTION

Avoid sudden stops and sharp turns. Avoid uneven terrain areas for loading and unloading.

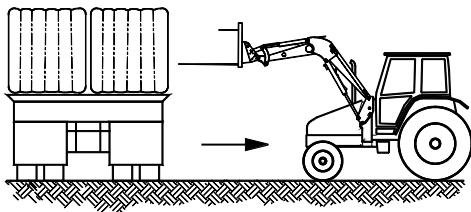

After setting the bale down position the A – frame with spear(s) horizontal to the ground and slowly back the tractor straight out.

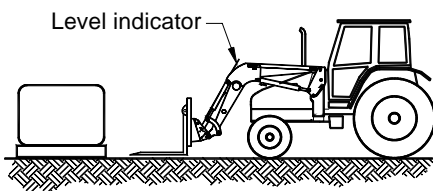

With pallet forks level and just above the ground, drive the forks into the pallet completely. Raise loader to lift pallet and carry level 6 to 12 inches off the ground.

Note: *The TSL loader is highly recommended when operating with pallet forks for maintaining a constant level load. Use the level indicator as a guide to ensure forks are level at ground.*

⚠ CAUTION

Avoid sudden stops and sharp turns. Operate at low ground speeds. Never attempt to lift loads heavier than the rated fork specs (42”– 2200 lbs.) (48”– 4400 lbs.). Always lift or carry pallets using both forks and utilizing the full length of the forks.

⚠ WARNING

When driving amongst livestock keep bucket cylinders retracted, and loader boom at least 6 to 7’ off the ground. Store A – frame away from both play and heavy traffic areas.

INSTALLING / REMOVING LOADER

Installing:

⚠ CAUTION Prior to initial mounting, cycle loader cylinders to displace air. This ensures the loader will remain in the storage position and operate consistently.

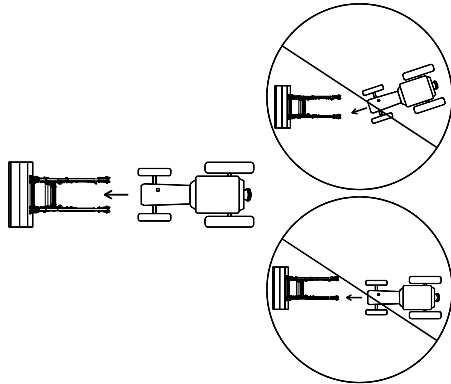

1. Position the tractor centrally and parallel to the loader uprights. Drive forward slowly until the loader hydraulic hoses can be coupled. Shut tractor off and set park brake. Couple the loader hoses to the matched color code identifiers on the auxiliary valve for proper orientation of loader operation.

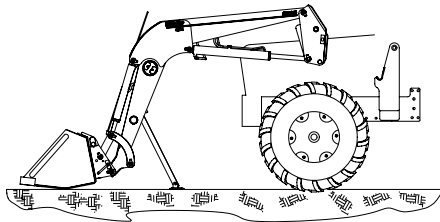

2. Extend lift cylinders to tilt both loader uprights approximately 30 degrees. Rollback bucket to further raise upright for additional clearance. Both upright base pivots must be above the loader mount cradle.

⚠ CAUTION Verify front and side clearances during installation to avoid tractor damage. Position hydraulic hoses such that they will not be pinched or stretched during installation.

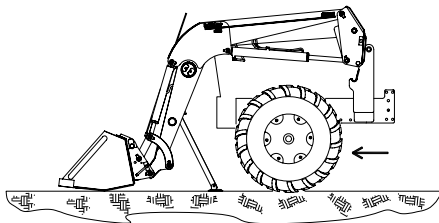

3. Slowly drive the tractor forward until the upright base pivot contacts the mount plate.

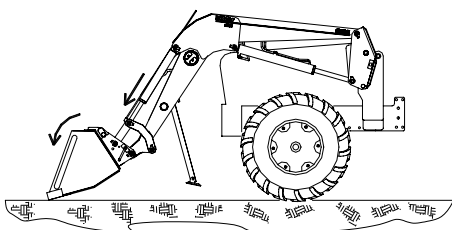

4. Slowly extend the bucket and retract the lift cylinders to lower the upright pivot into the mount plate cradle. Ensure both uprights are fully engaged within the mount plate cradle.

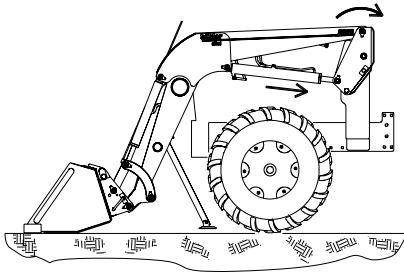

5. With the tractor in neutral, continue to retract the lift cylinders and extend the bucket cylinders to rotate the upright back against the lock pin stops. Shut the tractor off and set park brake.

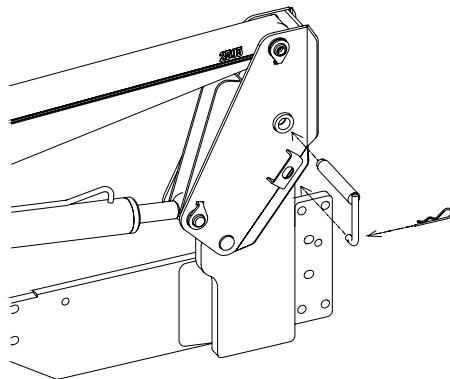

6. Install both upright attachment pins and secure with hairpin clip. Start the tractor and slowly raise loader until the parking stands are off the ground.

⚠ WARNING Shut tractor off and store parking stands within loader cross tube remembering to stand on the outside of the loader arms. Start the tractor and continue to cycle loader and attachment to verify loader operation.

Removing:

⚠ WARNING A bucket or other suitable attachment must be attached to the loader for stability. Always remove the loader on firm level surface away from children's play areas and high traffic areas.

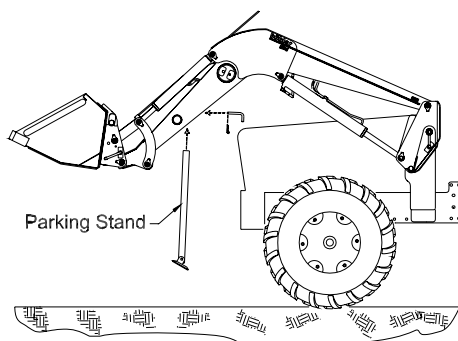

1. Raise loader to provide clearance to engage both parking stands. Shut off tractor. Standing along the outside of the loader arms remove parking stands from storage position and engage within the loader mainframe.

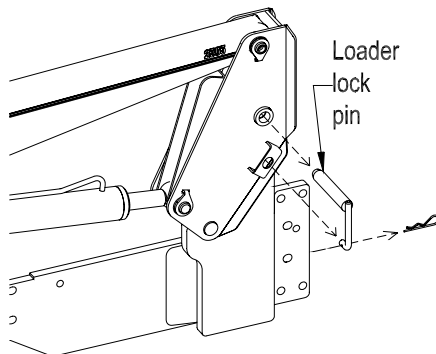

2. Lower attachment level to the ground while engaging float position. Ensure attachment rests firmly on ground with minimal downward pressure. If required extend bucket cylinders to rotate upright rearward. At this stage the pin should have no pressure. Set tractor park brake and remove loader lock pins. Check hydraulic hoses such that they will not get pinched or stretched during removal.

⚠ WARNING Operate hydraulic controls slowly. Loader will disengage from the mounting kit and may shift if not on firm level ground.

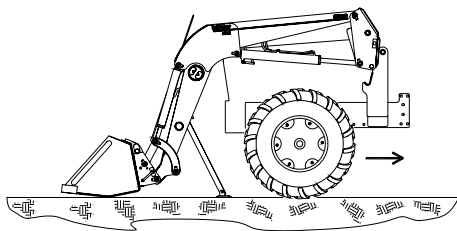

3. Retract bucket cylinders to raise upright and disengage from the loader mount cradle. If additional clearance is required, extend lift cylinders while slowly backing the tractor away from the loader.

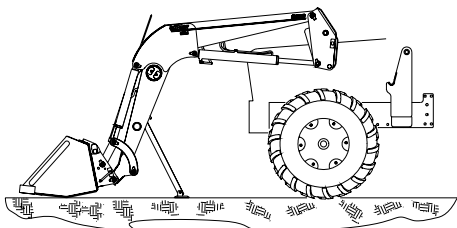

4. After the tractor is clear of the loader, retract all cylinders to protect the shafting. Shut tractor off and set park brake and relieve oil pressure in hoses by moving valve control. Disconnect hydraulic loader hydraulic hoses at the quick couplers. **IMPORTANT:** Cap both male and female couplers. Wrap loader hoses over loader arm.

LUBRICATION

Lubricate loader bushings and pivots every eight hours of average operation with high-grade grease. For grease fitting locations see illustration below. Select grease based on the expected outside temperature range. Lithium, Molybdenum and synthetic greases are preferred. Use the tractor hour meter as a guide. Increase lubrication intervals for extreme use or adverse conditions. Each pivot should be lubricated until grease is visible at pin.

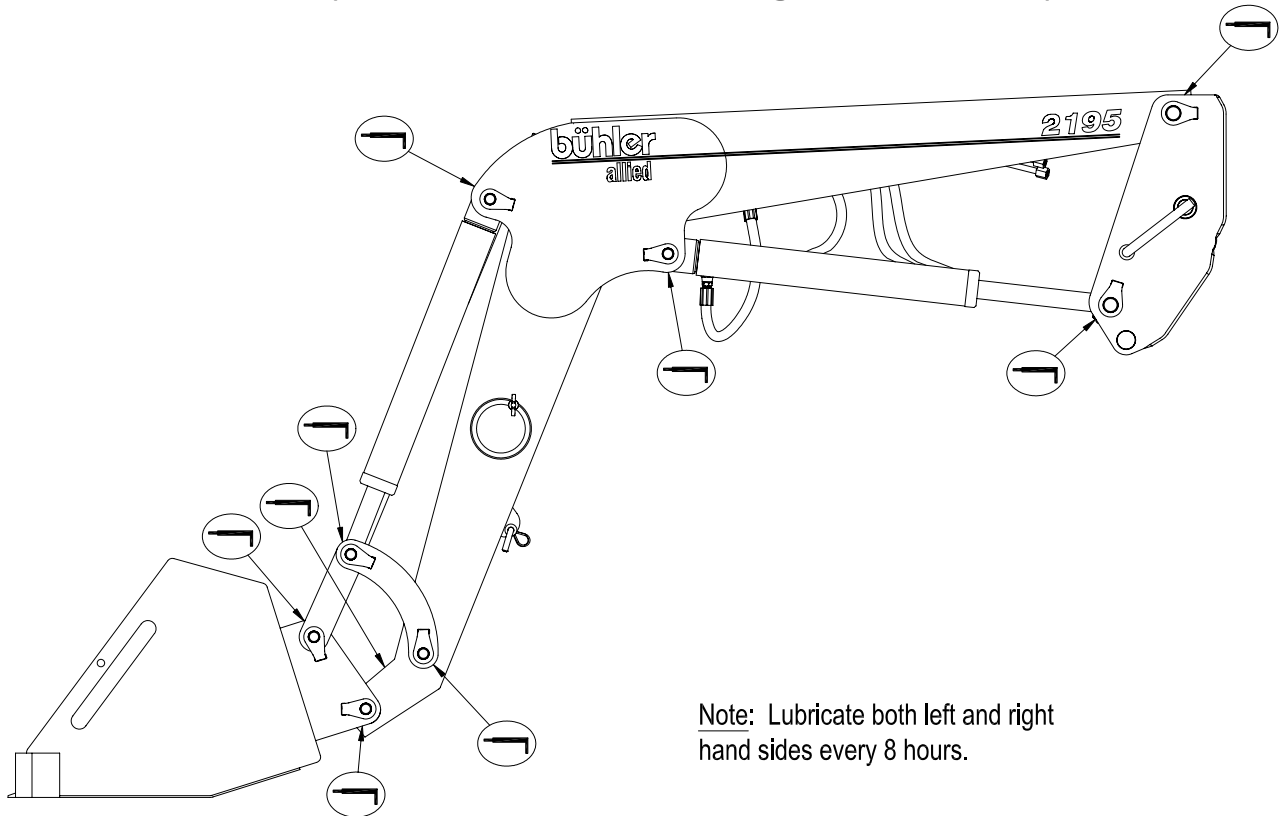

Note: Lubricate both left and right hand sides every 8 hours.

Standard Loader Shown

IMPORTANT: Ensure that grease fittings accept grease. Should any fitting become plugged, replace immediately. Pivots not greased as specified would cause premature wear of pins and bushings.

MAINTENANCE**General Inspection:**

⚠ CAUTION Lower attachment and loader to ground, place all controls in neutral, stop engine, set parking brake and remove ignition key before inspecting, servicing, adjusting or repairing loader.

⚠ WARNING Relieve hydraulic pressure before repairing, adjusting or disconnecting hydraulics components. Escaping hydraulic oil can penetrate skin causing serious personal injury. If injured consult a physician immediately.

⚠ WARNING Never work beneath a raised loader unless it is securely supported. The control lever can be moved or a hydraulic leak could cause the loader to drop resulting in serious injury or death. Refer to the *Lift Lock Instructions Decal* for proper use of the lift lock.

Lift Locks: The lift lock on your loader is to be used whenever someone is attempting to be under the loader or for tractor servicing. When using the locks ensure loader is free of any load in the loader attachment or no attachment.

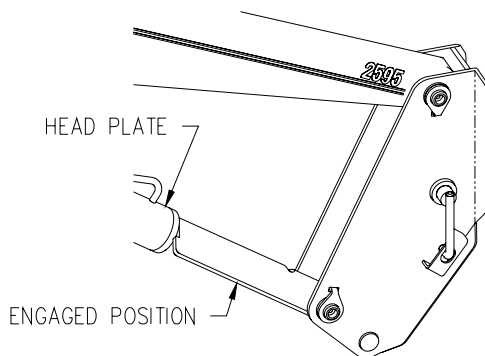

To engage, raise loader sufficient for lift lock clearance. Swing each lift lock forward resting on the cylinder rod below the head plate as shown. Turn off the tractor and slowly lower the loader until the cylinder head plate rests up against the lift lock. Then lock joystick in neutral position.

Pins and Bushings: Every 6 months or 1000 hours check loader and cylinder pivots for movement that would be due to bushing or pin wear. Change bushings when excessive movement is noticed and replace any worn or rough surfaced pins.

Mounting Kit:

After the initial 2 weeks or 40 hours of loader operation, and 6-month intervals thereafter re-torque all mounting kit bolts. (See below for proper bolt torques)

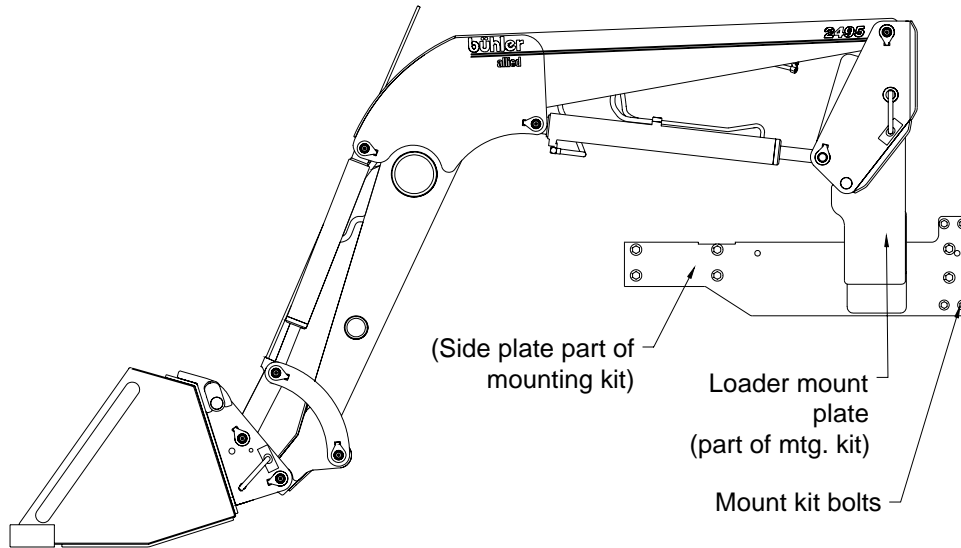

Bolt Torque Chart:

Standard						
Bolt Size (in.)	Grade 2 Bolts		Grade 5 Bolts		Grade 8 Bolts	
	Torque		Torque		Torque	
	ft-lbs	NM	ft-lbs	NM	ft-lbs	NM
0.25	6	7	8	11	12	16
0.313	11	15	17	23	25	33
0.375	20	27	31	42	44	60
0.438	32	43	49	66	70	95
0.5	49	66	76	103	106	144
0.563	70	95	109	148	153	207
0.625	97	131	150	203	212	287
0.75	144	195	266	360	376	509
0.875	166	225	430	583	606	821
1	250	339	644	873	909	1232
1.125	354	480	795	1077	1288	1745
1.25	500	678	1120	1518	1817	2462
1.375	655	887	1470	1992	2382	3228
1.5	870	1179	1950	2642	3161	4283

Metric									
Bolt Size (mm)	Class 5.6		Grade 8.8		Grade 10.9		Grade 12.9		
	Torque		Torque		Torque		Torque		
	ft-lbs	NM	ft-lbs	NM	ft-lbs	NM	ft-lbs	NM	
6	3.1	4.3	7.3	9.9	10.3	14	12.1	16.5	
8	7.7	10.5	17.7	24	25	34	29	40	
10	15	21	35	48	49	67	59	81	
12	26	36	61	83	86.2	117	103	140	
14	42	58	97	132	136	185	162	220	
16	64	88	147	200	210	285	250	340	
18	89	121	202	275	287	390	346	470	
20	126	171	287	390	405	550	486	660	
22	169	230	390	530	549	745	656	890	
24	217	295	497	675	708	960	840	1140	
27	320	435	733	995	1032	1400	1239	1680	
30	435	590	995	1350	1401	1900	1681	2280	
33	590	800	1349	1830	1902	2580	2278	3090	
36	759	1030	1740	2360	2441	3310	2935	3980	
39	988	1340	2249	3050	3163	4290	3798	5150	

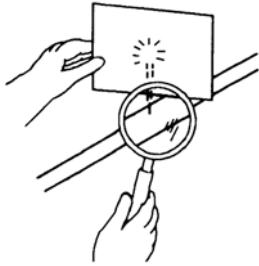
Hydraulics:

⚠ WARNING Escaping fluid under pressure can have sufficient force to penetrate the skin, causing serious personal injury. Before repairing, adjusting, or disconnecting lines, be sure to relieve all pressure.

Before applying pressure to the system, be sure all connections are tight and the lines, pipes, and hoses are not damaged.

Wear proper hand and eye protection when searching for leaks. Use a piece of wood or cardboard instead of hand to check for leaks.

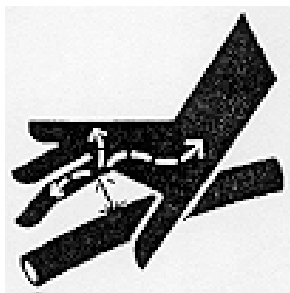

Maintain all components in good working order.

If injured by escaping fluid, see a doctor at once. Serious infection or toxic reaction can develop if proper medical treatment is not administered immediately.

With loader attachment on the ground, check and add if necessary the approved hydraulic fluid. Refer to the *Tractor Manual* for proper inspection of fluid level, oil type and service intervals. Visually check hoses and fittings for leaks and damage on a daily bases. Ensure hoses do not bind or stretch during operation. Always keep hoses tied or supported to prevent rubbing against sharp areas or being pinched. We suggest using tie wraps to support hoses. Hoses routed from steel lines to cylinders should be in a relaxed position. To correct, loosen swivel end of hose and retighten.

⚠ WARNING Never operate the loader with frayed or damaged hoses or leaking fittings. A burst would cause the loader to drop suddenly and result in serious injury or death and cause damage to the loader or tractor.

Replacement hoses must be equal to a working pressure of 3000 P.S.I. or higher.

A yearly inspection of the valve is recommended. However the maintenance intervals on the valve depends on the surrounding environment or if valve spools become stiff. Where temperatures fluctuate from one extreme to another or exposed to high salt the intervals for maintenance should be increased to protect from corrosion.

On non-cab tractors mounted with the joystick valve, slip back the boot and clean away any debris. Spray a corrosion resistant lubricant and remount the boot. Replace a torn or cracked boot.

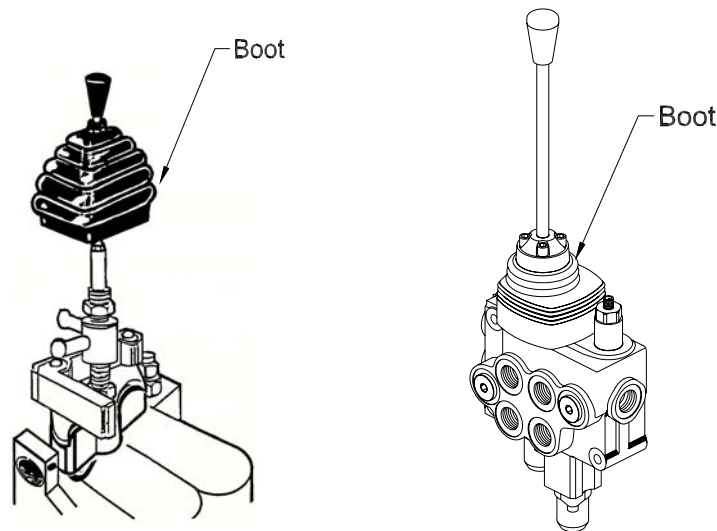

⚠ WARNING Shut tractor down and relieve oil pressure in system by moving the control valve spools in both directions before doing any maintenance.

Maintenance involves yearly removal of valve spool end caps and cleaning all debris and corrosion. Spray area with a corrosive resistant lubricant and recap.

⚠ CAUTION Never use grease to lubricate valve components where climate temperature drops below 0°C as this could cause spools to jam.

On valves fitted with joystick cables loosen off jam nut and cable sleeves to gain access to the valve spool. Clean all debris and any existing corrosion. Spray areas with a light corrosion resistant lubricant. Re-mount cables sleeves and adjust so that joystick is centered in both axis to the base. Lock cable sleeve by using the jam nut. *Note: In severe cold weather climates, inspect and maintain the valve and joystick cables before cold weather.*

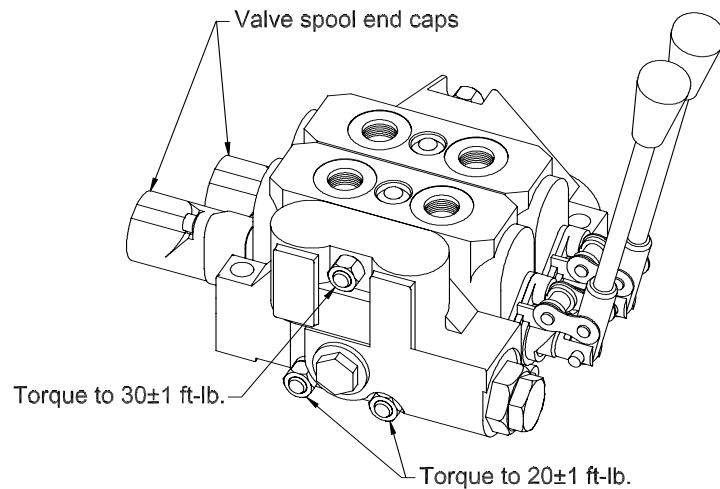
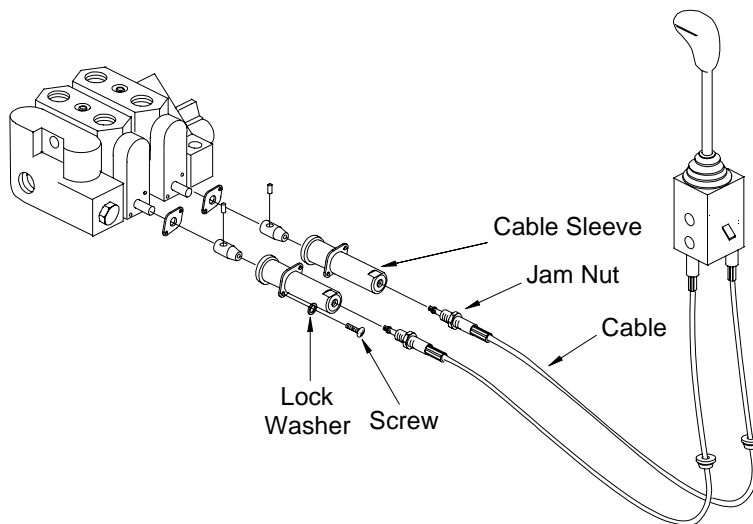

TROUBLE SHOOTING

<u>Problem</u>	<u>Possible Cause</u>	<u>Remedy</u>
Loader slow and/or will not dump.	Quick couplers leaking Hydraulic oil too heavy. Oil filter plugged. Hydraulic pump worn. Oil line restricted or leaking. Control valve does not shift properly. Air in hydraulic system. Cylinder leaks internally. Faulty valve.	Check connections and compatibility or replace. Change or replace filter. Clean or replace filter. Repair or replace pump. Check all hoses and tubes for leaks, damage or restrictions. Replace damaged or restricted hoses or tube lines. Inspect, clean, repair or replace valve. Cycle lift cylinders and bucket cylinders several times to free system of air. Replace seals. Repair or replace valve.
Loader chatters or vibrates when raising and lowering.	Air leak in pump inlet line. Air in hydraulic system. Oil level too low.	Check, tighten or replace inlet line. Cycle lift cylinders and bucket cylinders. Add oil as required.
Excessive movement at pivots.	Worn bushings and/or pins.	Replace bushings and/or pins.
Pump noisy.	Inlet line restricted or leaking. Oil level too low. Pump worn or damaged.	Check for air leaks, restrictions or collapsed hose. Tighten or replace hose. Clean filter if necessary. Add oil as required. Repair or replace pump.
Oil leaks.	Damaged fitting or hoses. Loose connections. Worn or damaged O-ring wiper seal in cylinder rod end. Worn or damaged O-rings in valve.	Replace damaged parts. Tighten fittings. Install a seal repair kit. Install an O-ring repair kit.

Trouble Shooting Continued

<u>Problem</u>	<u>Possible Cause</u>	<u>Remedy</u>
Insufficient lift capacity.	Improper hydraulic pump operation. Load is greater than boom lift capacity. Internal boom cylinder leakage. Improper hydraulic valve operation.	Repair or replace pump. Check loader specifications. Replace any worn parts and install a seal repair kit. Repair or replace valve.
Slow leak down.	Worn control valve. Worn cylinder piston seals.	Have authorized dealer replace seals.
Excessive wear on bottom oil bucket and wear pads.	Float position not used while operating loader.	Use float position provided on valve.
Hydraulic cylinders inoperative.	Hose from control valve improperly connected.	Refer to plumbing diagrams.
Pump operating continually on closed center tractor hydraulics system.	Tractor control valve relief stuck open. Incorrect Auxiliary Valve. Hydraulic control valve set to low.	See your service manual for proper adjustment. Check with loader dealer for proper valve application. Adjust valve in accordance with manual.
Loader lift and bucket tilt controls do not work according to decal.	Hoses improperly connected.	Refer to plumbing diagrams and correct hose connections.
Valve noisy and/or hot.	Open center control valve on closed center tractor.	Replace relief valve with closed center plug and plug the power beyond adapter on valve.
Tractor loads/pump squeals.	Closed center control valve on open center tractor.	Install open center plug on optional valve. Replace closed center plug with relief and install short plug in place of the power beyond adapter.
Stiff control valve.	Dirt or moisture build up on spool ends. Incorrect torque (applies to sectional valves only).	Clean spool ends and if applicable cable ends at valve. Loosen and re-torque bolts to specs.

PARTS APPENDIX

Description	Page
2195	
Notes	29
Main Frame Assembly	30
Hydraulic Plumbing	32
2195	
Cylinders	34
Hydraulic Fitting Torques	35
Prevailing Torque Locknuts	35
Notes	36

Notes:

2195 Main Frame Assembly

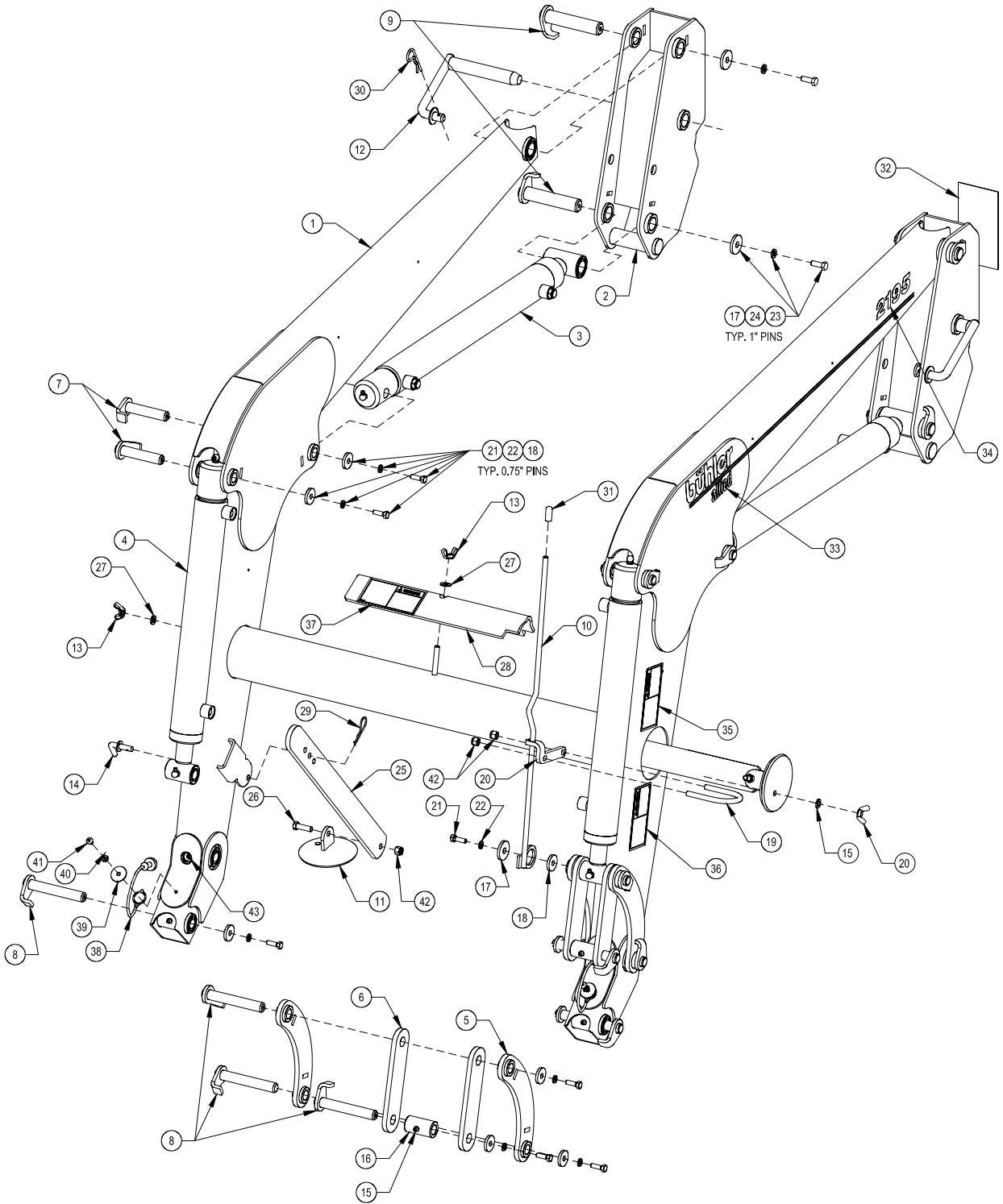

**2195
Main Frame Assembly**

Item	Part No.	Description	2195
1	25241	2195 Main Frame	1
2	25244	2095 / 2195 Upright	2
3	25538	2195 Lift Cylinder Assembly	2
4	25251	2195 Bucket Cylinder Assembly	2
5	116518	Link Weldment 2.0 x 8.50	4
6	116525	Link 2.0 x 6.13	4
7	116584	Pin Weldment 0.75 Dia x 4.0	4
8	116586	Pin Weldment 0.75 Dia x 5.25	8
9	116588	Pin Weldment 1.0 Dia x 5.125	4
10	116161	Leveling Rod Weldment	1
11	116864	Stand Foot Weldment	2
12	116219	Lock Pin Weldment	2
13	84217	3/8 Wing Nut	3
14	116226	Lock Pin Weldment	2
15	84583	Grease Fitting 1/8 NPTSTR Screw	2
16	116601	Linkage Spacer 0.76 ID x 2.25 LG	2
17	814319	Washer 0.44 ID x 1.50 OD x 0.19 TH	5
18	814320	Washer 0.38 ID x 1.25 OD x 0.19 TH	12
19	116047	U-Bolt 3/8 x 3.85	1
20	116164	Bracket Leveling Rod	1
21	812026	Hex Bolt – 0.313 UNC x 1.0	12
22	81569	Washer Lock 0.313 pl	12
23	86170	Hex Bolt – 0.375 UNC x 1.0	4
24	81593	0.375 Lock Washer	6
25	116221	Stand Leg	2
26	86171	Hex Bolt 0.375 x 1.25	2
27	84039	Washer Flat 0.375 pl	1
28	116569	Lift Lock	1
29	12780	Hair Pin Clip #7	2
30	12779	Hair Pin Clip #9	2
31	814333	Vinyl Cap	1
32	814366	Decal, General Warning	1
33	813356	Decal, "Buhler Allied"	2
34	814341	Decal, "2195"	2
35	112983	Decal, Warning Overhead Hazard	1
36	113711	Decal, Danger Electrocution Hazard	1
37	814307	Decal, Lift Lock Instructions	1
38	813424	Dust Plug ¼" – Red	2
39	812569	Fender Washer	2
40	81545	Washer Lock 0.25"	2
41	812520	Screw Phil 0.25 x 0.38	2
42	81344	Nut Lock (Nylon) 0.375nc	4
43	813914	Grease Fitting Straight 1/8 x 1.25	2

2195
Hydraulic Plumbing Assembly

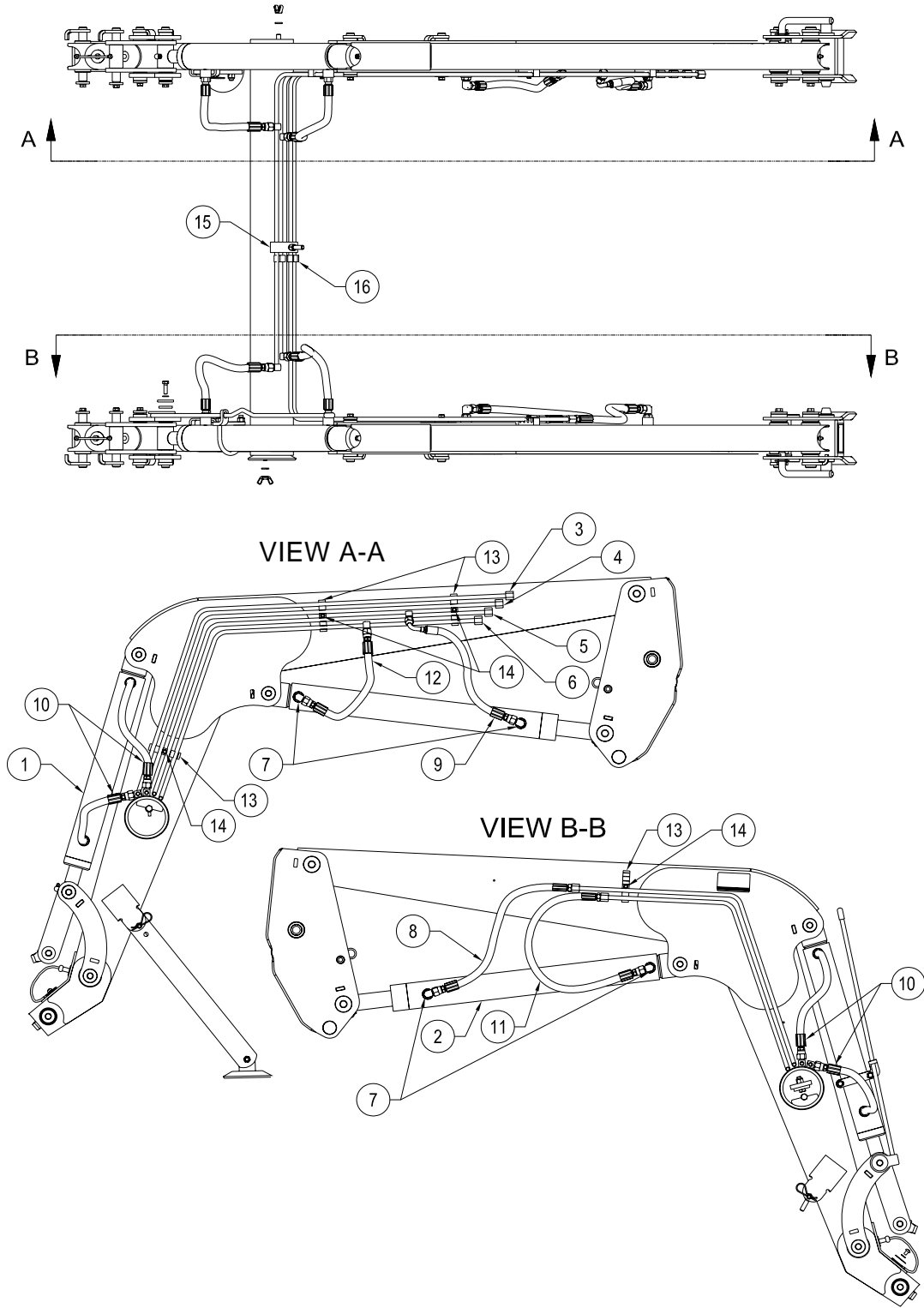

**2195
Hydraulic Plumbing Assembly**

Item	Part No.	Description	2195
1	Ref.	Bucket Cylinder (See cylinder assembly for breakdown)	2
2	Ref.	Lift Cylinder (See cylinder assembly for breakdown)	2
3	116591	Tube Bucket Cylinder Top (Rollback)	1
4	116592	Tube Bucket Cylinder Bottom (Dump)	1
5	116589	Tube Lift Cylinder Top (Lower)	1
6	116590	Tube Lift Cylinder Bottom (Raise)	1
7	811918	Elbow 90 9/16 Swmorb x 9/16 Mjic	4
8	116700	Hose 3/8 x 16-9/16 Mjic-Swfjic	1
9	116701	Hose 3/8 x 16-9/16 Swfjic-90 Deg. Swfjic	1
10	116702	Hose 3/8 x 16-9/16 Morb - Swfjic	4
11	116775	Hose 3/8 x 21-9/16 Mjic - Swfjic	1
12	813104	Hose 3/8 x 16-9/16 Swfjic	1
13	814318	Clip (Arm)	4
14	814317	Screw Sheet Metal #10 x 1.25 UNC	4
15	116220	Clip (Cross Tube)	1
16	814418	Rubber Clip (Cross Tube)	1

2195 Cylinder Assembly

	<u>Bucket Cylinders</u>	<u>Lift Cylinders Regular & TSL</u>
	<u>Regular</u>	<u>Regular</u>
Diameter	2.0"	2.0"
Length of Stroke	13.38"	18.50"
Retracted Length	23.63"	29.25"
Extended Length	37"	47.75"
Cylinder Assembly No.	25251	25538
Seal Kit No.	X1348	X1349
Shaft Diameter	1.25"	1.50"

<u>Item</u>	<u>Description</u>	<u>Part Number</u>	<u>Part Number</u>
1	Head Plate	24516	24522
2	Shaft Weldment	116603	116524
3	Cylinder Tube Weld't	25306	25237
4	Piston Half (Wide)	114520	114520
5	Piston Half (Narrow)	114521	114521
6	Self-Locking Nut	812655	812655
7	Shaft Bushing	116605	113577

NOTES:

1. Bucket cylinder shown
- *** 2. All cylinder seals are contained in corresponding seal kit.
3. Refer to page 38 for prevailing torque for locknuts.

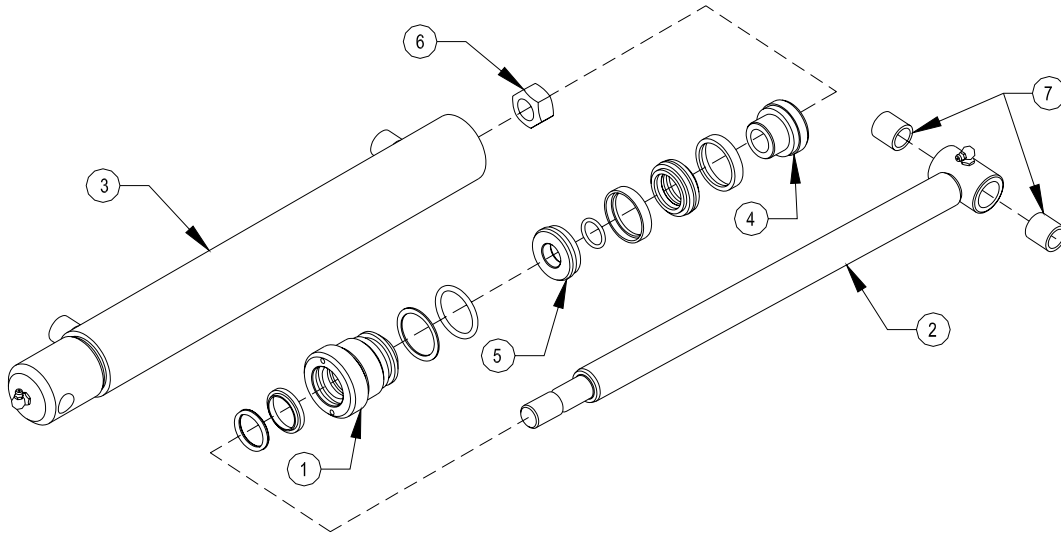

CAUTION Maximum pressure – 3000 psi

Hydraulic Fitting Torques:

Dash Size	Thread Size	Jam Nut or Straight		SAE 37° (JIC)	
		ORB Fitting Torque		Swivel Nut Torque	
		(ft-lbs)	(NM)	(ft-lbs)	(NM)
-04	7/16-20	14-16	20-22	10-11	13-15
-05	1/2-20	18-20	24-27	13-15	18-20
-06	9/16-18	24-26	33-35	17-19	23-26
-08	3/4-16	50-60	68-78	34-38	47-52
-10	7/8-14	72-80	98-110	50-56	69-76
-12	1-1/16-12	125-135	170-183	70-78	96-106
-14	1-3/16-12	160-180	215-245	80-90	110-122
-16	1-5/16-12	200-220	270-300	94-104	127-141
-20	1-5/8-12	210-280	285-380	124-138	169-188
-24	1-7/8-12	270-360	370-490	156-173	212-235

Prevailing Torque Locknuts:

Nut Size and Threads	Grade B Nuts		Grade C Nuts	
	Nut Tightening Torque		Nut Tightening Torque	
	(ft-lbs)	(NM)	(ft-lbs)	(NM)
Coarse Thread				
0.250-20	5-7	7-9	7-10	9-14
0.313-18	9-12.5	12-17	11-16	15-22
0.375-16	14.5-20	20-27	20-28	27-38
0.438-14	23-32	31-43	31-43	42-58
0.500-13	37-50	50-68	45-62.5	61-85
0.563-12	50-70	68-95	70-95	95-129
0.625-11	70-95	95-129	90-122.5	122-166
0.750-10	125-165	169-224	155-210	210-285
0.875-9	185-250	251-339	225-312.5	305-423
1.000-8	275-375	373-508	360-462.5	488-627
Fine Thread				
0.250-28	5.5-7.5	7-10	7-10	9-14
0.313-24	10-13	14-18	12-17	16-23
0.375-24	16-22	22-30	21-29	28-39
0.438-20	24-34	33-46	31-43	42-58
0.500-20	37.5-52.5	51-71	50-70	68-95
0.563-18	57.5-77.5	78-105	70-95	95-129
0.625-18	72.5-97.5	98-132	90-125	122-169
0.750-16	120-165	163-224	155-210	210-285
0.875-14	200-270	271-366	225-312.5	305-423
1.000-14	300-400	407-542	362.5-500	491-678

Notes:

- 1) For Grade A locknut torque specifications refer to Grade B specifications.

Notes:

WARNING!

LOOK OUT FOR CHILDREN.
TEACH YOUR CHILDREN SAFETY.
(INFORM THEM OF DANGERS AROUND MACHINES)

MANUAL MUST BE READ AND
UNDERSTOOD BY OPERATOR.

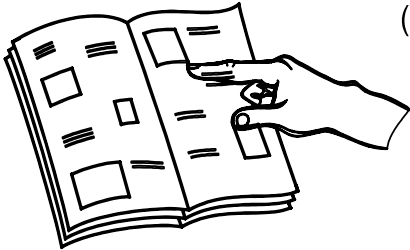

TRANSPORT

EMBLEMS MUST BE VISIBLE

ALWAYS MOVE EQUIPMENT IN
LOW OR DOWN POSITION
ESPECIALLY AROUND POWER LINES.

NEVER LEAVE EQUIPMENT IN
RAISED POSITION.

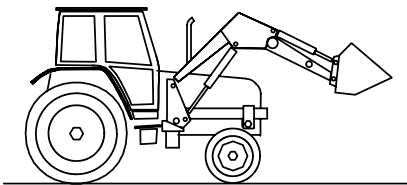
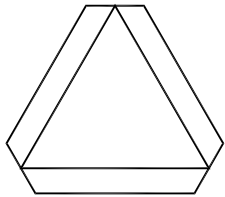

POWER LINES
CAN KILL

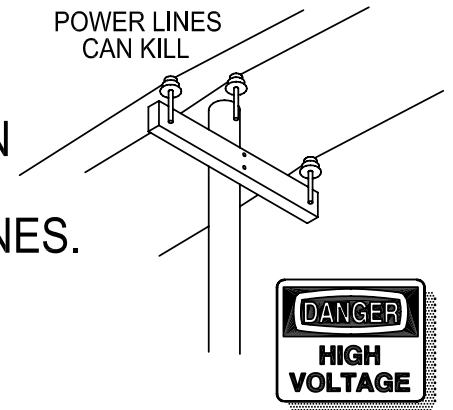

SERVICE

SERVICE EQUIPMENT ONLY
WHEN STOPPED AND WITH
LIFT LOCKS IN PLACE AS SHOWN.

KEEP ALL GUARDS AND
SHIELDS IN PLACE.

REPLACE DAMAGED OR WORN
PARTS. FRAYED CABLES AND
HOSES ARE DANGEROUS.

DO NOT CHANGE FACTORY SETTINGS.

KEEP DECALS CLEAN AND LEGIBLE.
(REPLACEMENTS NORMALLY AVAILABLE)

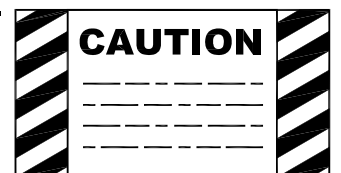
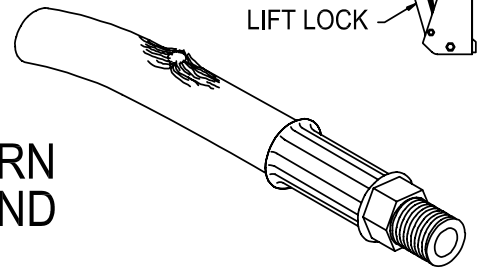
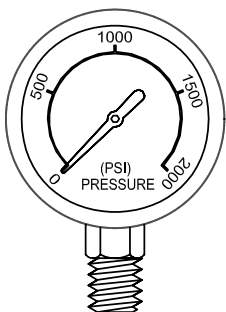
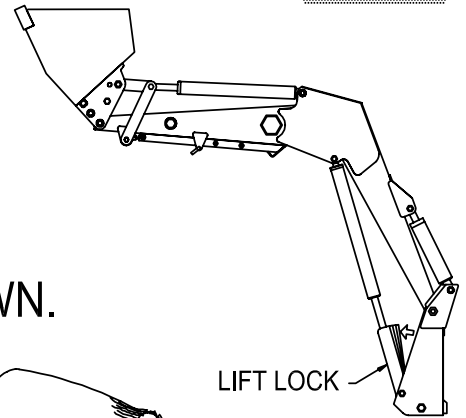
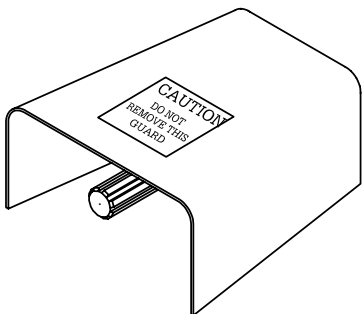

DIVISION LOCATIONS

Allied Division
1201 Regent Ave. W.
Box 1003
Winnipeg, MB R2C 3B2
Ph.: (204) 661-8711
Fax: (204) 654-2503

Farm King Division
301 Mountain Street S.
Morden, MB R6M 1X7
Ph.: (204) 822-4467
Fax: (204) 822-6348

Inland Division
675 Washington Ave.
Winnipeg, MB R2K 1M4
Ph: (204) 667-7854
Fax: (204) 669-2599

B.I.I. Division
1330 43rd Street N.W.
Fargo, ND 58102
Ph: (701) 282-7014
Fax: (701) 282-5865

CANADIAN WAREHOUSES

B.C., Abbotsford
(604) 864-2665

AB, Edmonton
(403) 962-6991

SK, Regina
(306) 781-2300

ON, Woodstock
(519) 539-0435

ON, Jasper
(613) 283-1758

QC, Dorion
(450) 455-4840

U.S. WAREHOUSES

AR, West Memphis
(870) 732-3132

GA, Stone Mountain
(770) 908-9439

IA, Atlantic
(712) 243-5520

IA, Lakeview
(712) 657-8585

ID, Meridian
(208) 887-6006

IL, Hooppole
(815) 948-2591

IL, LeRoy
(309) 962-8414

IN, Clarksville
(812) 284-3376

IN, Crawfordsville
(317) 362-4495

KS, Wichita
(765) 265-9577

MN, Lakeville
(952) 469-5267

MT, Billings
(406) 248-7771

NE, Gothenburg
(308) 537-7175

NC, Dunn
(910) 892-8500

NC, Statesville
(704) 873-0531

ND, Bismarck
(701) 223-1886

ND, Fargo
(701) 282-7003

NY, Oneida
(315) 363-3390

NY, Syracuse
(315) 463-5276

OH, Youngstown
(330) 793-0862

OR, Portland
(503) 234-0378

SD, Huron
(605) 352-8616

TX, Houston
(713) 928-2632

UT, Salt Lake City
(801) 972-4321

WI, Portage
(608) 742-1370

OFFSHORE WAREHOUSES

Burando Hill
Katanning
W. Australia
011-618-98-214422

Chihuahua, Mexico
011-52-158-90306

John Kerr Equipment Ltd.
Wilcoxholm Farm
Linlithgow, W. Lothian
Scotland
011-441-506-842280

Skovde, Sweden
011-46-500-452651

Naestved, Denmark
011-45-557-29511

bühler

Buhler Manufacturing *"a partnership"*

1201 Regent Ave. W.
Winnipeg, MB.
R2C 3B2
Ph.: (204) 661-8711
Fax: (204) 654-2503
www.buhler.com