

bühler

farm king

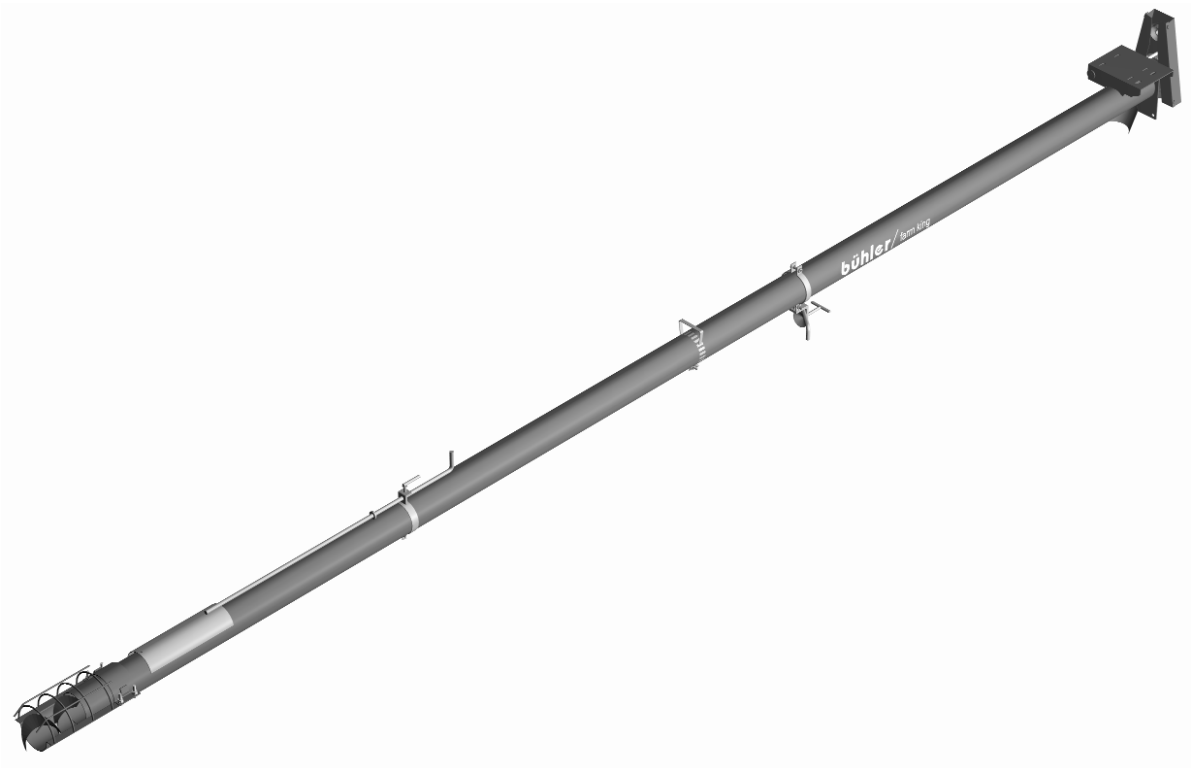

4" Utility Auger

Operator's and Parts Manual
FK338

2008

TABLE OF CONTENTS

DESCRIPTION	PAGE
WARRANTY	1
INTRODUCTION	2
SAFETY	3
Safety	3
General Safety	4
Start Up Safety	4
Operation Safety	4
Service and Maintenance Safety	4
Storage Safety	5
Safety Signs	5
Safety Sign Installation	5
ASSEMBLY	7
Assembly Instructions	7
OPERATION	8
Theory of Operation	8
MAINTENANCE	9
Bolt Torque	9
PARTS DRAWINGS	10
4" Utility Auger Parts List	10
4" Utility Auger Drawing	12
SHIPPING KIT AND BUNDLE NUMBERS	13

WARRANTY POLICY

Buhler Manufacturing products are warranted for a period of twelve (12) months (90 days for commercial application) from original date of purchase, by original purchaser, to be free from defects in material and workmanship under correct, normal agricultural use and proper applications.

Buhler Manufacturing's obligations under this warranty shall be limited to the repair or exchange, at Buhler Manufacturing's option, of any Buhler Manufacturing product or part which proves to be defective as provided. Buhler Manufacturing reserves the right to either inspect the product at the buyer's location or have it returned to the factory for inspection.

The above warranty does not extend to goods damaged or subject to accident, abuse or misuse after shipment from Buhler Manufacturing's factory, nor to goods altered or repaired by anyone other than an authorized Buhler Manufacturing representative.

Buhler Manufacturing makes no Express Warranties other than those, which are specifically described. Any description of goods, including any references and specifications in catalogues, circulars and other written material published, is for the sole purpose of identifying goods and shall conform to such descriptions. Any sample or model is for illustrative purposes only and does not create an Express Warranty that the goods conform to sample or model shown.

The purchaser is solely responsible for determining suitability of goods sold. This warranty is expressly in lieu of all other warranties expressed or implied. Buhler Manufacturing will in no event be liable for any incidental or consequential damages whatsoever. Nor for any sum in excess of the price received for the goods for which liability is claimed.

WARRANTY CLAIMS:

Warranty requests must be prepared on Buhler Manufacturing Warranty Claim Forms with all requested information properly completed. Warranty Claims must be submitted within a thirty (30) day period from date of failure repair.

WARRANTY LABOR:

Any labor subject to warranty **must** be authorized by Buhler Manufacturing. The labor rate for replacing defective parts, where applicable, will be credited at 100% of the dealer's posted shop rate. Defective parts will receive an extra 10% discount to assist with freight or other incidental costs.

GOVERNMENT LEGISLATION:

Warranty terms and conditions are subject to Provincial or State legislation.

IMPORTANT FACTS:

Buckets and Bucket Tines Carry No Warranty
Bent Spears Carry No Warranty
Snowblower Fan Shafts Carry No Warranty
Mower Blades Carry No Warranty
Portable Auger Parts Have Two (2) Year Warranty
Loader Parts Have Two (2) Year Warranty

IMPORTANT NOTE: This warranty does not apply to rentals

INTRODUCTION

The Buhler Farm King Utility Augers offer heavier gauge tubing to assure extra durability. The flow control gives you quick and easy regulation of grain flow, and allows the auger to be cleaned out prior to shut down. The intake flighting on all augers is protected by an intake guard to prevent injuries. Belt guards are standard on all units.

All Buhler Farm King Utility Augers feature adjustable motor mounts, so you can choose the size and brand of electrical motor to suit your needs. Auger pulleys are supplied on all sizes.

Keep this manual handy for frequent reference. All new operators or owners must review the manual before using the equipment and at least annually thereafter. Contact your Buhler Dealer if you need assistance, information, or additional copies of the manual. Visit our website at www.buhler.com for a complete list of dealers in your area.

The directions left, right, front and rear, as mentioned throughout this manual, are as seen facing in the direction of travel of the implement.

SAFETY INSTRUCTIONS

Remember, YOU are the key to safety. Good safety practices not only protect you, but also the people around you. Make these practices a working part of your safety program. Be certain that everyone operating this equipment is familiar with the recommended operating and maintenance procedures and follows all the safety precautions. Most accidents can be prevented. Do not risk injury or death by ignoring good safety practices.

The alert symbol is used throughout this manual. It indicates attention is required and identifies hazards. Follow the recommended precautions.



The safety alert symbol means...

ATTENTION! BECOME ALERT! YOUR SAFETY IS INVOLVED!



CAUTION

The caution symbol indicates a potentially hazardous situation that, if not avoided, may result in minor or moderate injury. It may also be used to alert against unsafe practices.



WARNING

The Warning Symbol indicates a potentially hazardous situation that, if not avoided, could result in death or serious injury, and includes hazards that are exposed when guards are removed. It may also be used to alert against unsafe practices.



DANGER

The Danger Symbol indicates an imminently hazardous situation that, if not avoided will result in death or serious injury. This signal word is to be limited to the most extreme situations, typically for machine components that, for functional purposes, cannot be guarded.

GENERAL SAFETY INSTRUCTIONS

Have a first-aid kit available for use and know how to use it.

Have a fire extinguisher available, stored in a highly visible location, and know how to use it.

Wear appropriate protective gear. This list may include but is not limited to:

- Hard hat
- Protective shoes with slip resistant soles
- Protective glasses or goggles
- Heavy gloves
- Wet weather gear
- Hearing protection
- Respirator or filter mask

Read and understand the Operator's Manual and all safety signs before operating, servicing, adjusting, repairing, or unplugging the equipment.

Do not attempt any unauthorized modifications to your Buhler product as this could affect function or safety, and could affect the life of the equipment.

Inspect and clean the working area before operating.

Keep hands, feet, clothing, and hair away from moving parts.

Ensure bystanders are clear of the area before operating.

START-UP SAFETY

Do not let inexperienced operators or children run this equipment.

Ensure all shields are in place and in good condition before operating.

Make certain electric motors are grounded.

OPERATION SAFETY

Do not wear loose fitting clothing during operation.

Do not allow anyone other than the operator close to the Auger when in operation.

SERVICE AND MAINTENANCE SAFETY

Stop engine, set brake, remove ignition key, and wait for all moving parts to stop before servicing, adjusting, repairing, or unplugging.

Support the equipment with blocks or safety stands before working beneath it.

Follow good shop practices including

- Keep service area clean and dry
- Be sure electrical outlets and tools are properly grounded
- Use adequate light for the job

Use only tools, jacks, and hoists of sufficient capacity for the job.

Replace and secure all shields removed during servicing before operating.

Use heavy leather gloves to handle sharp objects.

STORAGE SAFETY

Store the unit in an area away from human activity.
Do not permit children to play on or around the stored machine.
Support the frame on stands and blocks to provide a secure base.

SAFETY SIGNS

The following illustration shows the approximate location and detail of safety signs. Keep all safety signs clean and legible and replace any that are damaged or missing. When original parts are replaced, any safety signs affixed to those parts should be replaced as well. Replacement safety signs are available from your local dealer.

INSTALLATION OF SAFETY SIGNS

To install safety signs, ensure the installation area is clean and dry. Decide on the exact position before you remove the backing paper. Remove the smallest portion of the split backing paper and align over the specified area. Carefully press in place. Slowly peel back the remaining paper and smooth the remaining portion in place. Small air pockets can be pierced with a pin and smoothed out.

4" UTILITY AUGER

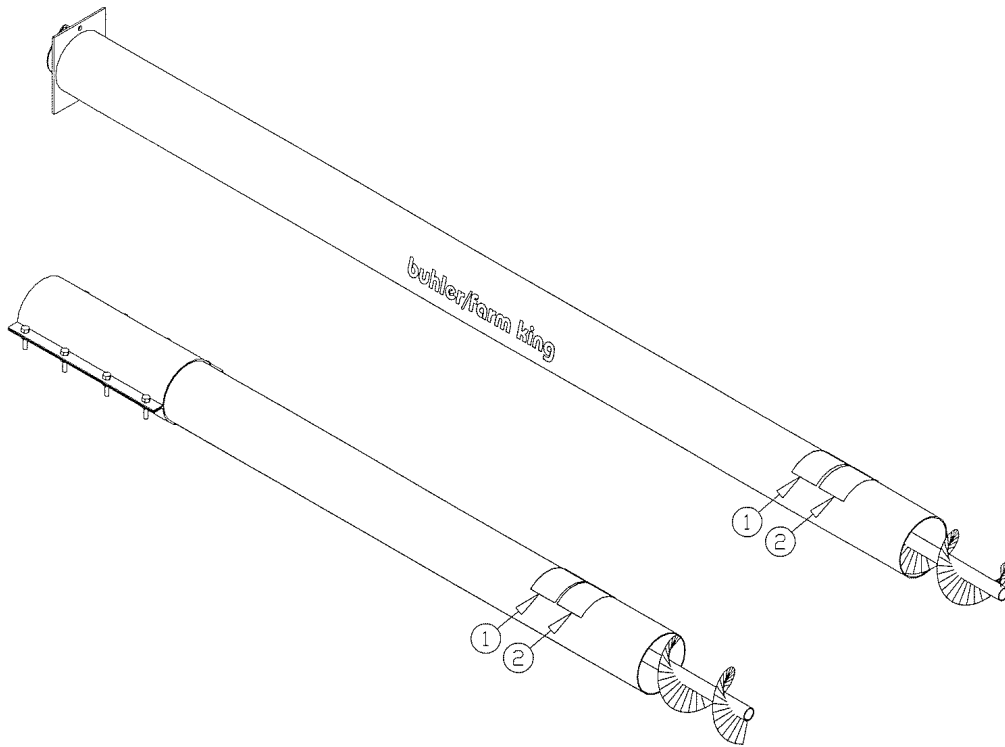

UA-02

SAFETY DECALS

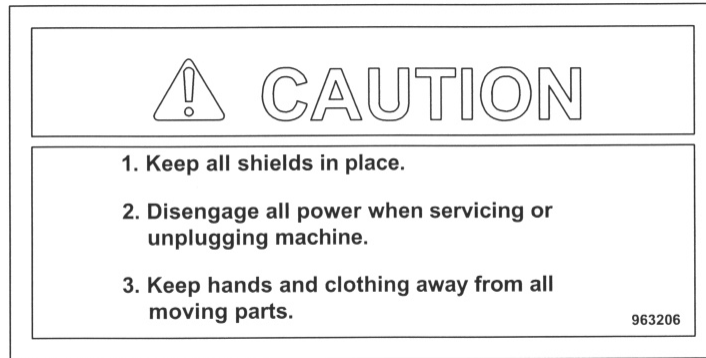

#1



#2

Replace safety signs immediately should they become damaged, torn or illegible. Obtain replacements from your authorized dealer using the part numbers shown.

ASSEMBLY INSTRUCTIONS

1. Fasten motor mount (#11) with $\frac{1}{2}$ " x $7 \frac{3}{8}$ " pin (#37) and a cotter pin (#38) to the welded brackets at the top of the motor mount plate.
2. Mount 6" sheave (#4) using key (#16) and set screw supplied with sheave.
3. Fasten grain deflector (#12) with $\frac{1}{4}$ " x $\frac{3}{4}$ " bolt (#21) and hex nut (#17).
4. Assemble box clamp (#8) on auger tube using existing bolts supplied with box clamp.
5. Attach handle (#3) with $\frac{5}{16}$ " x $1 \frac{1}{2}$ " stove bolt (#14) and a wing nut (#15).
6. Fasten intake bottom plate (#24) using an intake clamp (#25) with $\frac{5}{16}$ " x $1 \frac{1}{4}$ " bolts (#13), lock washers (#23) and hex nuts (#18).
7. Mount the 2" sheave (#5) on an electric motor and assemble motor with belt (#6) on the motor mount. Be certain that the belt is sufficiently tight before assembling pulley guard.
8. Use a flat washer (#41) and a hex nut (#33) to fasten the belt guard (#7) to the motor mount. Bolt the left (#29) and the right (#30) guard back plates to the guard using $\frac{1}{4}$ " x $\frac{1}{2}$ " bolts (#35), lock washers (#36) and hex nuts (#17).

OPTIONAL FEED CONTROL



Fasten feed control clamp (#26) approximately 37" from intake end of auger tube.

OPERATION INSTRUCTIONS

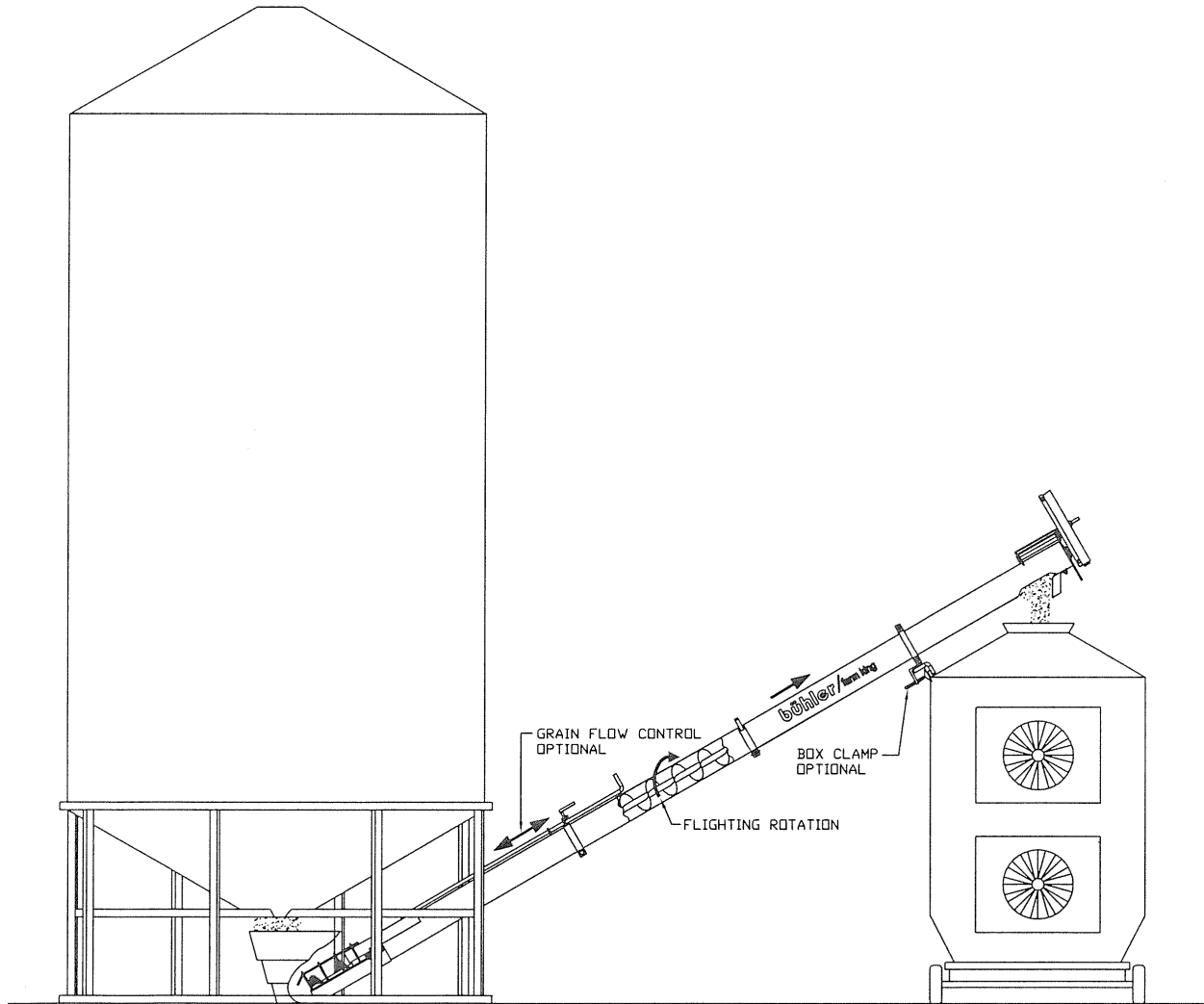
THEORY OF OPERATION

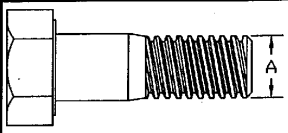
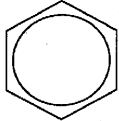

MAINTENANCE

Bolt Torque						
						
Bolt Diameter	SAE2		SAE5		SAE8	
"A"	N.m	lb-ft	N.m	lb-ft	N.m	lb-ft
1/4"	8	6	12	9	17	12
5/16"	13	10	25	19	36	27
3/8"	27	20	45	33	63	45
7/16"	41	30	72	53	100	75
1/2"	61	45	110	80	155	115
9/16"	95	70	155	115	220	165
5/8"	128	95	215	160	305	220
3/4"	225	165	390	290	540	400
7/8"	230	170	570	420	880	650
1"	345	225	850	630	1320	970

WHEN ORDERING PARTS

Always give your dealer the Model, Color and Serial Number of your machine to assist him in ordering and obtaining the correct parts. Use the exploded view and tabular listing of the area of interest to exactly identify the required part.

4" UTILITY AUGER

ITEM	PART #	DESCRIPTION
1	905681	4" x 10' Tube
	905682	4" x 15' Tube
	905683	4" x 20' Tube
2	963104	4" x 11' Flighting
	963105	4" x 16' Flighting
	963106	4" x 21' Flighting
3	963107	Handle
4	963110	6" Sheave - 3/4" Bore
5	963111	2" Sheave - 5/8" Bore
6	963112	Belt (A-26)
7	905686	Belt Guard
8	963133	Box Clamp Assembly
	963134	Box Clamp
9	963135	Pipe Clamp
10	963136	Clamp Swivel
11	905679	Motor Mount ('04 & Up)
12	963117	Grain Deflector
13	81552	5/16" x 1 1/4" Hex Bolt (pl)
14	967111	5/16" x 1 1/2" RD HD Stove Bolt (pl)
15	968601	5/16" Wing Nut
16	902944	6" Sheave Key
17	81544	1/4" Hex Nut (pl)
18	81568	5/16" Hex Nut (pl)
19	811795	3/8" x 2" Hex Bolt
20	81592	3/8" Hex Nut (pl)
21	81525	1/4" x 3/4" Hex Bolt (pl)
22	81553	5/16" x 1 1/2" Hex Bolt (pl)
23	81569	5/16" Lock Washer (pl)
24	963141	Intake Bottom Plate
25	963142	Intake Clamp
26	963144	Clamp Only
27	963145	Screw Only
28	963146	Feed Control Slide Only
29	905684	Belt Guard Back Section (Left Hand)

30	905685	Belt Guard Back Section (Right Hand)
31	963130	3/4" Bearing c/w Collar
32	963131	3/4" Flange (47MST)
33	81614	7/16" Hex Nut (pl)
34	81549	5/16" x 3/4" Hex Bolt (pl)
35	81523	1/4" x 1/2" Hex Bolt (pl)
36	81545	1/4" Lock Washer (pl)
37	902996	Heavy Duty Motor Mount Pin
38	9812430	1/8" x 1" Cotter Pin (pl)
39	907986	1/2" X 2 1/2" Hex Bolt Full Thread (pl)
40	81636	1/2" Hex Nut (pl)
41	84048	1/2" BS Flat Washer
42	963121	4" x 10' Tube
43	963123	4" Extension Coupling
44	963122	4" x 10' Flighting
45	9812348	1/4" x 1 1/4" Gr. 8 Hex Bolt (pl)
46	84498	1/4" Lock Nut (pl)
47	902971	9 1/8" X 23 1/2" Top Section
48	902972	8 5/8" x 16 7/8" Bottom Section
49	952050-000	39 1/2" Chain
50	967168	Pop Rivets (AD56BS)
51	981358	1/8" BS Flat Washer (pl)
52	902965	4" Spout
53	905690	1" X 7 1/2" Spout Clamp

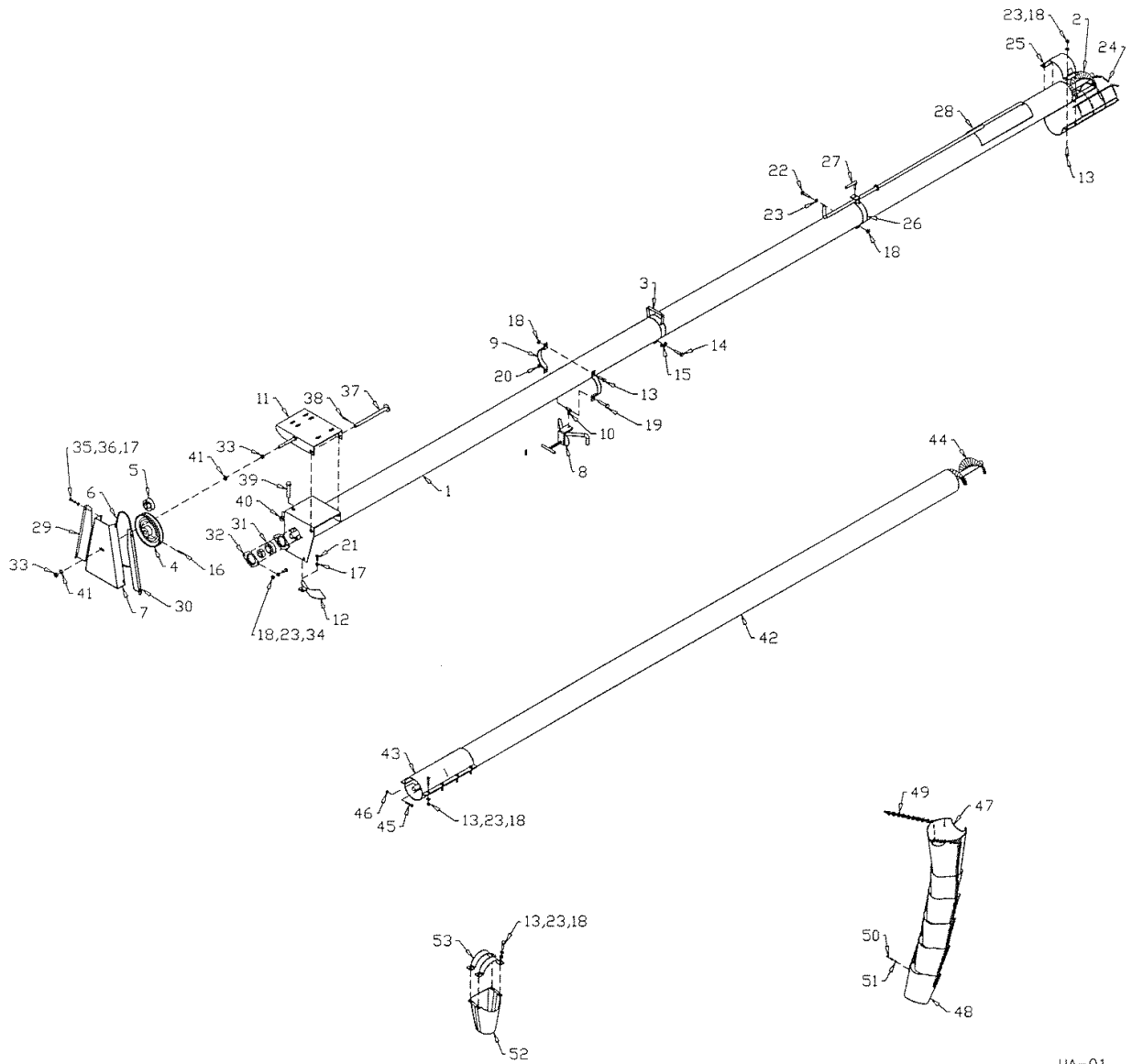

UA-01

SHIPPING KIT AND BUNDLE NUMBERS

The following is a list of Kit Numbers for this product and the Bundle Numbers, Descriptions, and Quantities for each Kit.

QUANTITY	BUNDLE NO.	DESCRIPTION
Y411 4" x 11' UTILITY AUGER		
1	F0102	4" x 11' utility Auger
1	F0105	Carton of Parts
Y416 4" x 16' UTILITY AUGER		
1	F0103	4" x 16' Utility Auger
1	F0105	Carton of Parts
Y421 4" x 21' UTILITY AUGER		
1	F0104	4" x 21' Utility Auger
1	F0105	Carton of Parts

OPTIONAL BUNDLE NUMBERS

The following is a list of options available for the Kits listed above.

F1030	4" x 10' Extension
F1002	4" Flow Control
F3001	4" Flex Spout
F0106	4" Bolt-on Spout
F215	Mini Poly Hopper

DIVISION LOCATIONS

Farm King Division
301 Mountain Street S.
Morden, MB R6M 1X7
Ph.: (204) 822-4467
Fax: (204) 822-6348

Allied/Inland Division
1260 Clarence Avenue
Winnipeg, MB R3T 1T2
Ph.: (204) 284-6100
Fax: (204) 477-2325

B.I.I. Division
1330 43rd Street N.W.
Fargo, ND 58102
Ph: (701) 282-7014
Fax: (701) 282-5865

U.S. WAREHOUSES

AR, West Memphis
(870) 732-3132

GA, Stone Mountain
(770) 908-9439

ID, Meridian
(208) 887-6006

IN, Clarksville
(812) 284-3376

KS, Wichita
(316) 265-9577

MN, Lakeville
(952) 469-5267

MT, Billings
(406) 248-7771

ND, Bismarck
(701) 223-1886

ND, Fargo
(701) 282-7003

NE, Blair
(402) 426-8211

OH, Youngstown
(330) 793-0862

OR, Beaverton
(503) 641-1865

SD, Huron
(605) 352-8616

TX, Houston
(713) 928-2632

UT, Salt Lake City
(801) 972-4321

WI, Portage
(608) 742-1370

CANADIAN WAREHOUSES

B.C., Abbotsford
(604) 864-2665

AB, Edmonton
(780) 962-6991

SK, Regina
(306) 781-2300

ON, Woodstock
(519) 539-0435

QC, Dorion
(450) 455-4840

OFFSHORE WAREHOUSES

Burando Hill
Katanning
W. Australia
011-618-98-214422

Chihuahua, Mexico
011-52-158-90306

John Kerr Equipment Ltd.
Wilcoxholm Farm
Linlithgow, W. Lothian
Scotland
011-441-506-842280

Skovde, Sweden
011-46-500-452651

Naestved, Denmark
011-45-557-29511

bühler

Buhler Manufacturing

**301 Mountain Street S.
Morden MB.
R6M 1X7
Ph.: (204) 822-4467
Fax: (204) 822-6348
www.buhler.com**